



HARTNER



Vorstellung neuer Produkte

Das neue umfangreiche VHM Fräserprogramm 2016/2017!

29.07.2016 | AB



HARTNER

TOPLine



BASICLine



HARTNER

TOPLine

TF 100 U

- mit ungleicher Teilung und Zentrumschnitt
- für Werkstoffe bis 54 HRC

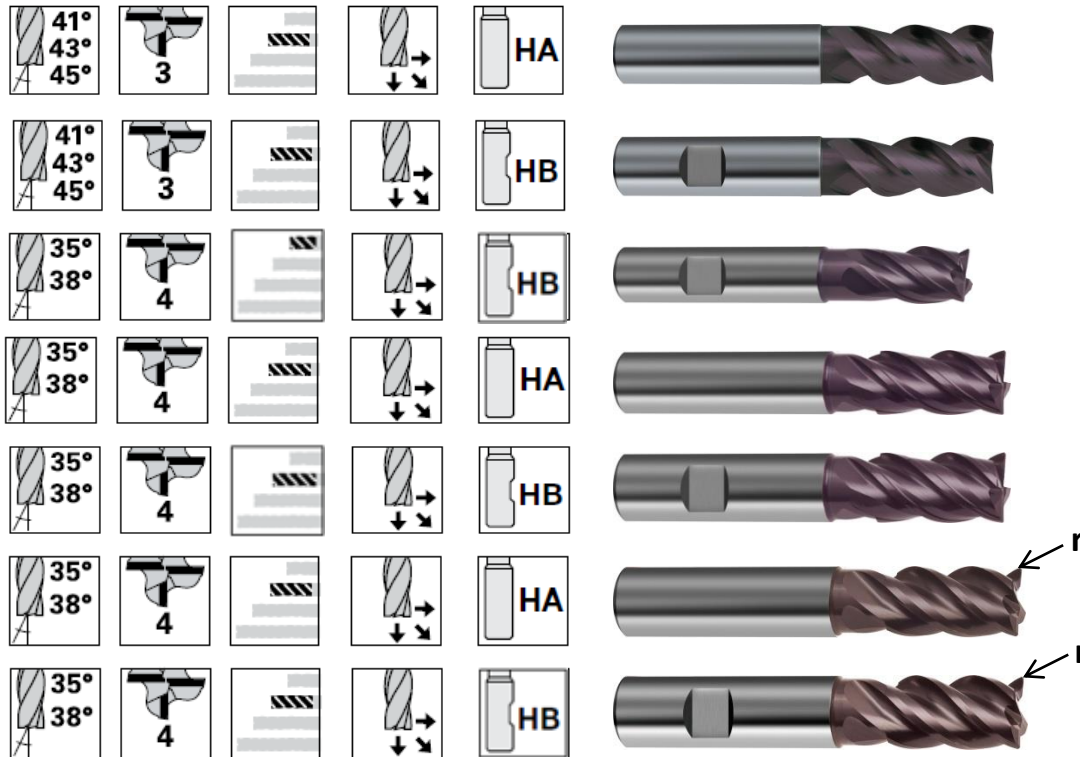

VHM	F	84952	Ø 3,0 – 20	NEW
VHM	F	84953	Ø 3,0 – 20	NEW
VHM	F	84900	Ø 3,0 – 20	NEW Abmessungen!
VHM	F	84901	Ø 3,0 – 25	NEW Abmessungen!
VHM	F	84902	Ø 3,0 – 25	NEW Abmessungen!
VHM	A	84954	Ø 6,0 – 25	NEW
VHM	A	84955	Ø 6,0 – 25	NEW



HARTNER

TOPLine

TF 100 U

- mit ungleicher Teilung und Zentrumschnitt
- für Werkstoffe bis 54 HRC

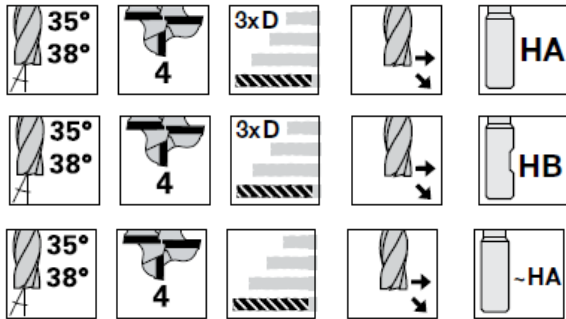

HA



HB



-HA

VHM



84956 Ø 6,0 – 20



VHM



84957 Ø 6,0 – 20



VHM



84980 Ø 10 – 25



TF 100 MULTI-MILL

- multifunktionaler Hochleistungsfräser zum Rampen, Bohren, Nuten, Schruppen und Schlichten

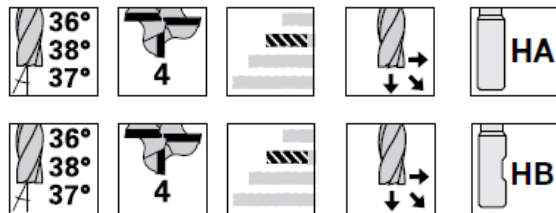

HA

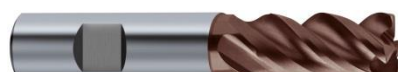

HB

VHM



84951 Ø 6,0 – 20

VHM



84950 Ø 6,0 – 20



TOPLine

TF 100 INOX

- mit ungleicher Teilung und Zentrumschnitt
- für rostfreie Stähle

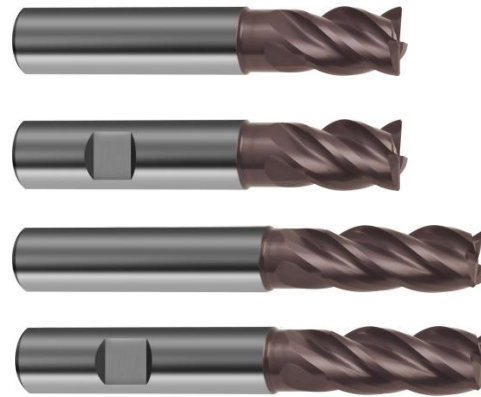
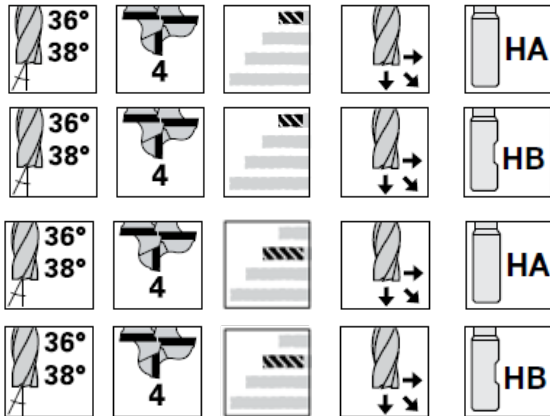

VHM	a	84958	Ø 4,0 – 20	NEW
VHM	a	84959	Ø 4,0 – 20	NEW
VHM	a	84972	Ø 3,0 – 25	NEW
VHM	a	84973	Ø 3,0 – 25	NEW

HS 100 U

- mit ungleicher Teilung und Zentrumschnitt
- für rostfreie Stähle + allgemeine Stähle, Schruppen



VHM	a	84974	Ø 5,0 – 25	NEW
VHM	a	84975	Ø 5,0 – 25	NEW



HARTNER

TOPLine

TF 100 SF

- Superfinish mit Zentrumschnitt

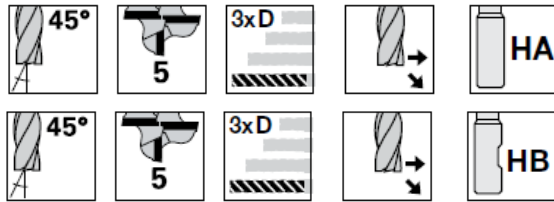

VHM	F	84976	Ø 4,0 – 20	NEW
VHM	F	84977	Ø 4,0 – 20	NEW

HP 100 U

- Superfinish mit Zentrumschnitt
- für Materialien bis 54 HRC

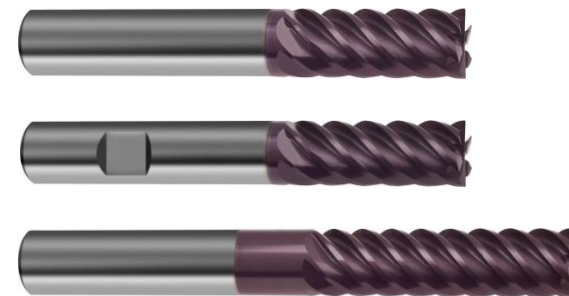
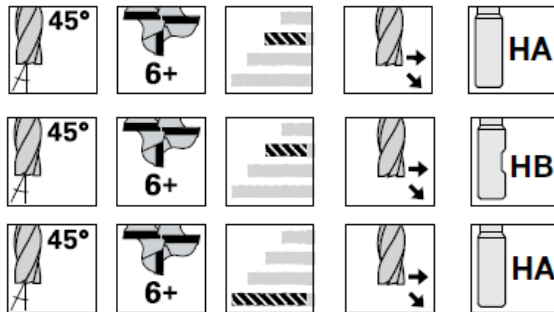

VHM	F	84908	Ø 3,0 – 25
VHM	F	84909	Ø 6,0 – 20
VHM	F	84910	Ø 6,0 – 20



HARTNER

TOPLine

TF 100 W

Nuten, Schruppen und Schichten in Aluminium und Al-Legierungen, Kunststoffen und Nicht-Eisen-Metallen

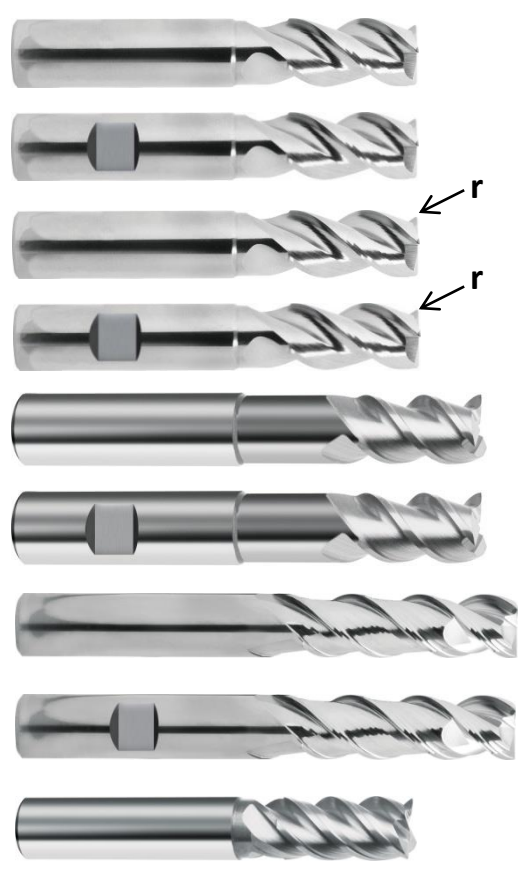
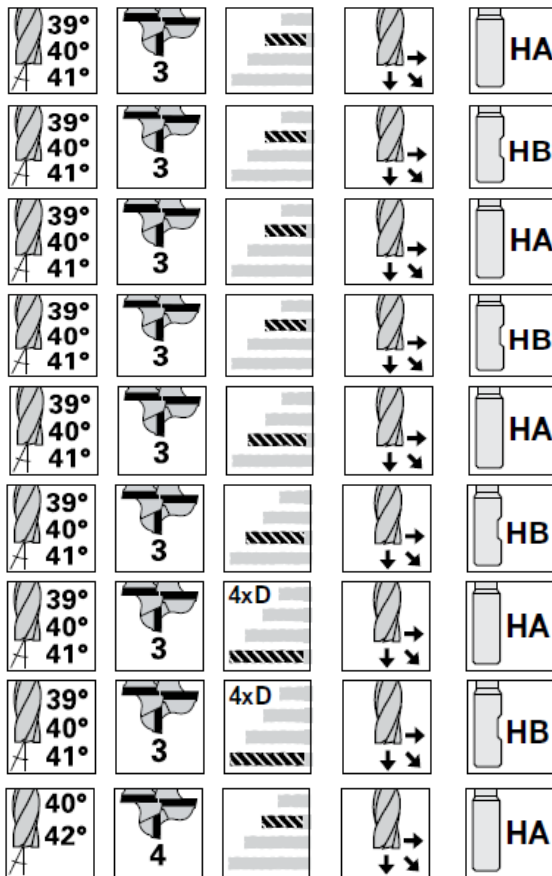

VHM		84960	Ø 3,0 – 20	
VHM		84961	Ø 3,0 – 20	
VHM		84962	Ø 6,0 – 25	
VHM		84963	Ø 6,0 – 25	
VHM		84964	Ø 6,0 – 20	
VHM		84965	Ø 6,0 – 20	
VHM		84966	Ø 6,0 – 20	
VHM		84967	Ø 6,0 – 20	
VHM		84968	Ø 3,0 – 20	



HARTNER

TOPLine

TP 100 W

- Nuten, Schruppen und Schlichten
- in Aluminium und Al-Legierungen, Kunststoffen und Nicht-Eisen-Metallen, mit Innenkühlung



VHM



84970 Ø 6,0 – 25

NEW

HP 100 H

- Hart-Kopierfräser mit Vollradius für Stähle bis 63 HRC

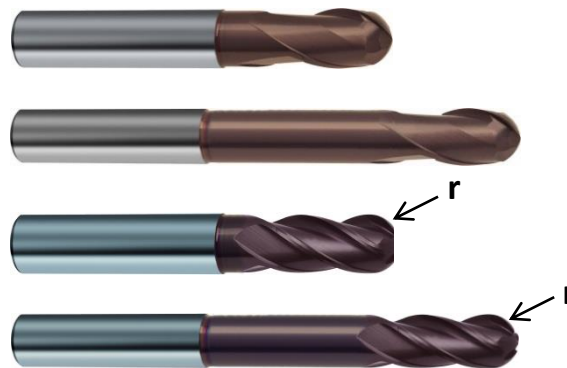
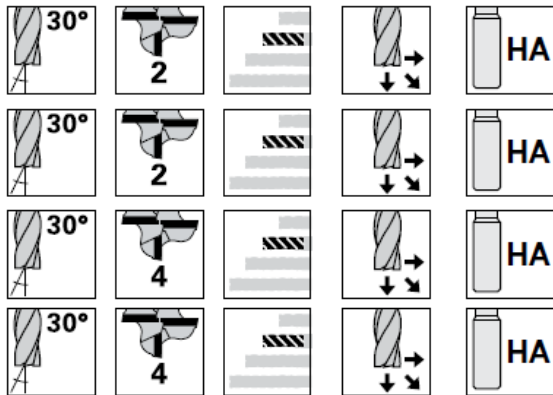

VHM



84934 Ø 0,5 – 16

NEW

VHM



84935 Ø 3,0 – 16

NEW

VHM



84938 Ø 2,0 – 12

NEW

VHM



84939 Ø 2,0 – 12

NEW



HARTNER

TOPLine

HP 100 H

- Hart-Kopierfräser für Stähle bis 63 HRC

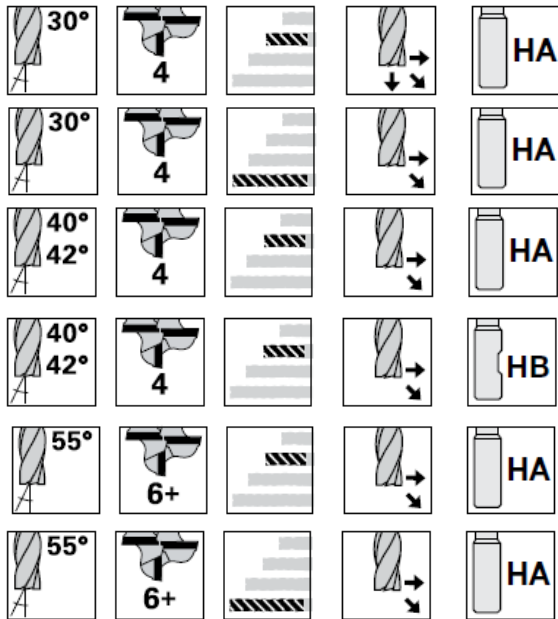

VHM		84930	∅ 3,0 – 16	
VHM		84931	∅ 6,0 – 16	
VHM		84936	∅ 6,0 – 20	
VHM		84937	∅ 6,0 – 20	
VHM		84932	∅ 3,0 – 20	
VHM		84933	∅ 6,0 – 20	



HARTNER

BASICLine

Fasfräser

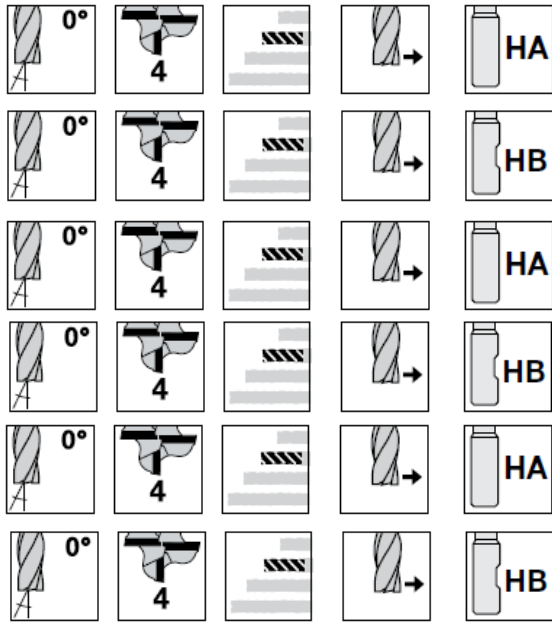

60°

VHM



84921 Ø 4,0 – 12



60°

VHM



84922 Ø 4,0 – 12



90°

VHM



84923 Ø 4,0 – 12



90°

VHM



84924 Ø 4,0 – 12



120°

VHM



84925 Ø 4,0 – 12



120°

VHM



84926 Ø 4,0 – 12

Al Langlochfräser (2-Schneider)

- mit Zentrumschnitt



VHM



84914 Ø 3,0 – 20



VHM



84940 Ø 3,0 – 20

NEW Abmessungen!

NEW



BASICLine

Langlochfräser (2-Schneider)

- mit Zentrumschnitt
- für Materialien bis 1200 N/mm²

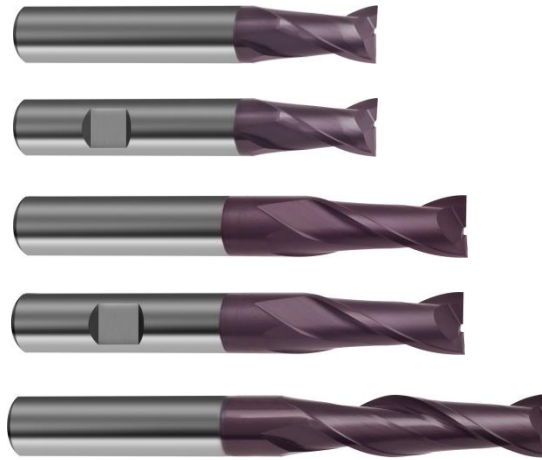
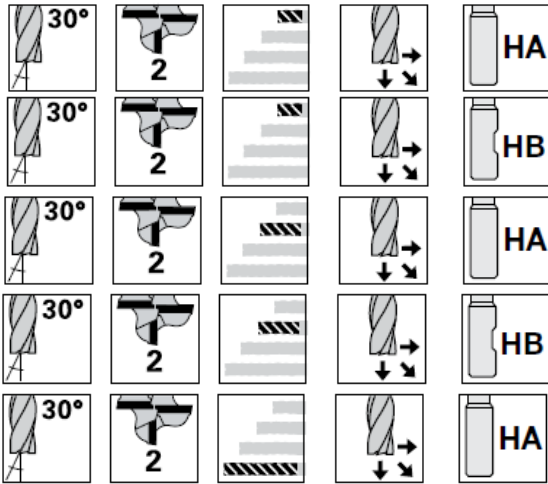

VHM	F	84942 Ø 2,0 – 20	NEW
VHM	F	84943 Ø 2,0 – 20	NEW
VHM	F	84911 Ø 2,0 – 12	
VHM	F	84912 Ø 2,0 – 20	
VHM	F	84913 Ø 3,0 – 20	

Mini-Bohrnutenfräser (3-Schneider)

- mit Zentrumschnitt

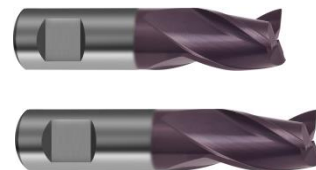
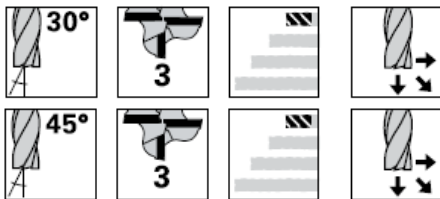

VHM	F	84945 Ø 1,0 – 20	NEW
VHM	F	84905 Ø 1,0 – 10	



HARTNER

BASICLine

Bohrnutenfräser (3-Schneider)

- mit Zentrumschnitt
- für Materialien bis 1400 N/mm²

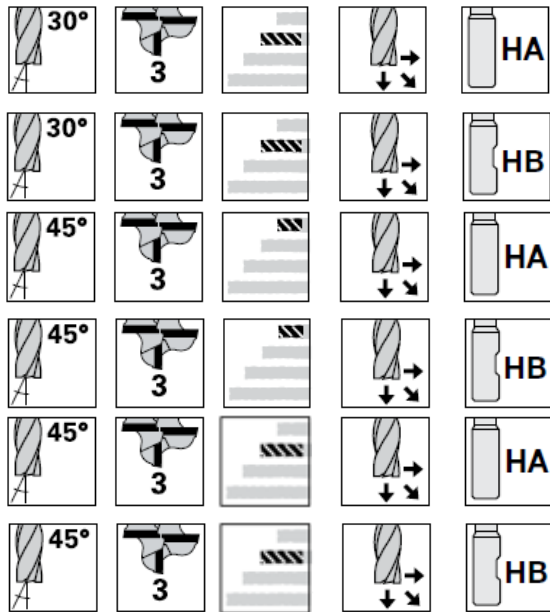

VHM	F	84946 Ø 2,0 – 20	NEW
VHM	F	84947 Ø 2,0 – 20	NEW
VHM	F	84948 Ø 3,0 – 20	NEW
VHM	F	84949 Ø 3,0 – 20	NEW
VHM	F	84903 Ø 3,0 – 20	
VHM	F	84904 Ø 3,0 – 20	NEW

NEW Abmessungen!



HARTNER

BASICLine

Schafffräser (4-Schneider)

- mit Zentrumschnitt

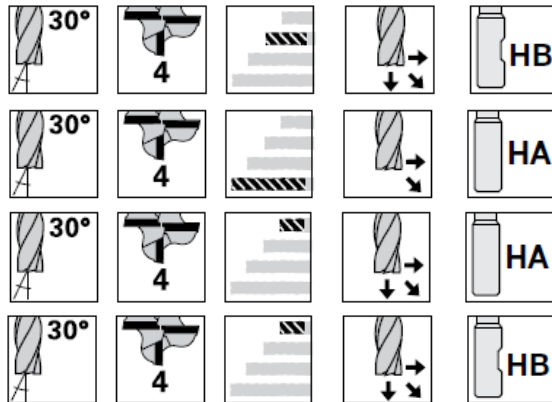

VHM



84915 Ø 2,0 – 20

VHM



84916 Ø 3,0 – 20

VHM



84944 Ø 2,0 – 20

NEW

VHM



84941 Ø 2,0 – 20

NEW



BASICLine

Schruppfräser HS 100 U

- feinverzahnt (4-5 Schneiden)
- für Materialien bis 1200 N/mm²



VHM



84906 Ø 6,0 – 20

Schruppfräser HS 100 H

- feinverzahnt (4-5 Schneiden)
- für normale und hochfeste Werkstoffe bis 54 HRC



VHM



84907 Ø 6,0 – 20

Kopierfräser mit Vollradius (2 und 4 Schneiden)

- mit Zentrumschnitt
- für Materialien bis 1200 N/mm²



VHM



84917 Ø 0,5 – 20



VHM



84918 Ø 4,0 – 12



VHM



84919 Ø 3,0 – 20



Fräsersätze in Dosen

- 5 Fräser DIN 6527 L
- Ø6,0 | 8,0 | 10,0 | 12,0 | 16,0 mm
- (84927 1,0 mit 4: Ø6,0 | 8,0 | 10,0 | 12,0 mm)
- Preisvorteil gegenüber Einzelkauf!



TF 100 U

mit # 84902



F 84920 1,0

mit # 84953



F 84927 1,0 **NEW**

TF 100 INOX

mit # 84973



a 84928 1,0 **NEW**

TF 100 W

mit # 84961



○ 84997 1,0 **NEW**

TF 100 MULTI-MILL

mit # 84951



Y 84999 2,0 **NEW**

mit # 84950



Y 84998 2,0 **NEW**

HS 100 U

mit # 84975



a 84929 1,0 **NEW**



HARTNER

**Neuer Fräserkatalog 2016
in Kürze verfügbar!**

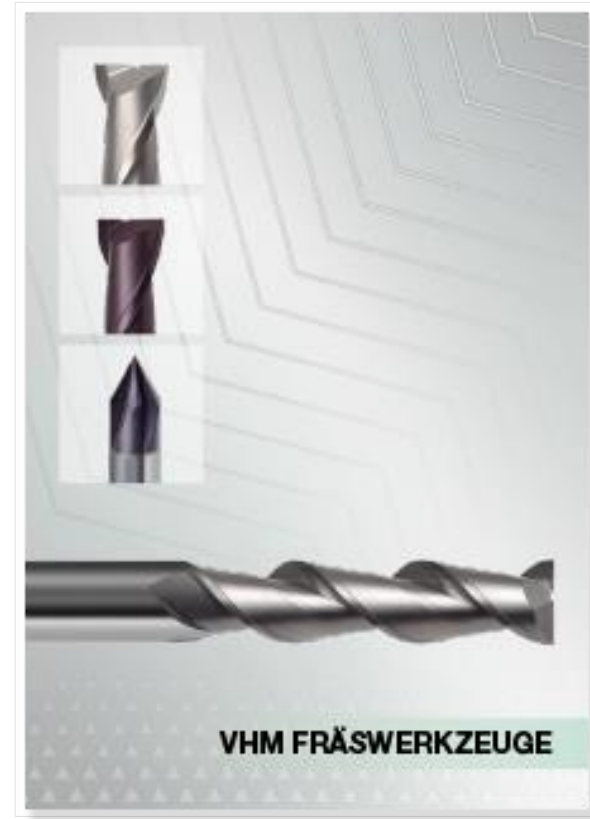



HARTNER

LAGERVERFÜGBARKEIT AB JULI 2016!

