

Werkzeugaufnahmen

DIN 69871

Toolholders

DIN 69871

Porte-outils

DIN 69871





Burg Hohenzollern
Castle Hohenzollern
Château de Hohenzollern

Werkzeugaufnahmen

DIN 69871

Toolholders

DIN 69871

Porte-outils

DIN 69871





Vorgewuchtet
Pre-balanced
Pré-équilibré

G 6,3 15.000 min⁻¹

G 2,5 Feinwuchten gegen Aufpreis
G 2,5 Fine balancing at extra charge
G 2,5 Equilibrage fin contre un supplément

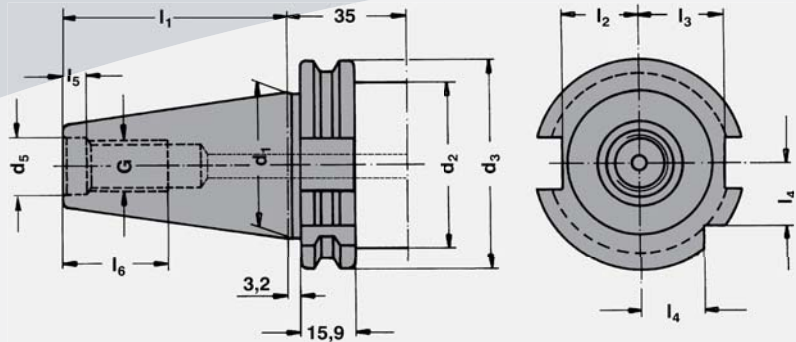

SK	d ₁	G	d ₅	d ₂	d ₃	l ₁	l ₂	l ₃	l ₄	l ₅	l ₆	d ₆	e
30	31,75	M12	13	45	50,00	47,80	16,4	19,0	15,0	5,5	24	M4	21
40	44,45	M16	17	50	63,55	68,40	22,8	25,0	18,5	8,2	32	M4	27
50	69,85	M24	25	80	97,50	101,75	35,5	37,7	30,0	11,5	47	M6	42

Mit innerer Kühlmittelzufuhr über den Bund - Form AD/B

With internal coolant through the collar - form AD/B
Avec arrosage interne par la collerette - forme AD/B

Bei Lieferung mit Gewindestiften verschlossen
Delivery with headless screws in closed position
Livraison en état fermé avec de vis sans tête

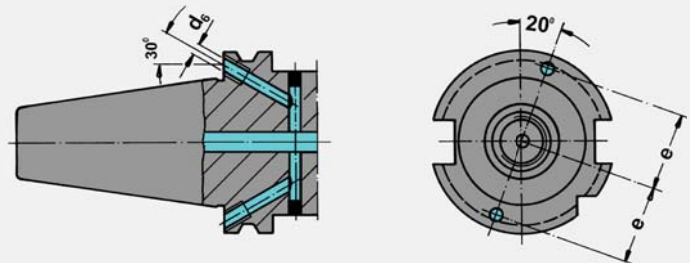

Werkstoff: Legierter Einsatzstahl mit einer Zugfestigkeit im Kern von min. 1200 N / mm². Einsatzgehärtet HRC 60 ± 2 (HV 700 ± 50), Härtetiefe 0,8 mm ± 0,2 mm, brüniert und präzisionsgeschliffen.

Form AD/B: Lieferung in Ausführung AD, Form B mit lösbaren Gewindestiften verschlossen.

Genauigkeit: Kegelwinkel – Toleranzqualität < AT 3 nach DIN 7187 und DIN 2080.

Material: Alloyed case-hardened steel, tensile core strength of min. 1200 N / mm². Case hardened HRC 60 ± 2 (HV 700 ± 50), hardening depth 0.8 mm ± 0.2 mm, black-finished and precisely grinded.

Form AD/B: Delivery in form AD, type B closed with releasable headless screws.

Accuracy: Quality of taper < AT 3 according to DIN 7187 and DIN 2080.

Matière: Acier de cémentation allié. Résistance à la traction dans le noyau de min 1200 N / mm². Cémentation à HRC 60 ± 2 (HV 700 ± 50), profondeur de cémentation 0,8 mm ± 0,2 mm, bruni et rectifié précisément.

Forme AD/B: Livraison en forme AD, forme B fermée avec de vis sans tête amovibles.

Précision: Qualité du cône < AT 3 selon DIN 7187 et DIN 2080.

Inhaltsverzeichnis

Index

Table de matières

DIN 69871



1



1.05



1.06



1.10



1.11



1.13



1.14



1.15



1.22



1.24



1.25



1.27



1.29



1.30



1.31



1.33



1.35



1.36



1.37



1.38



1.40



1.45



Verwendung:
Zur Aufnahme von Werkzeugen mit Zylinderschaft in Spannzangen.

Application:
For mounting straight-shank tools in collets.

Application:
Pour le serrage d'outils avec queue cylindrique dans des pinces de serrage.

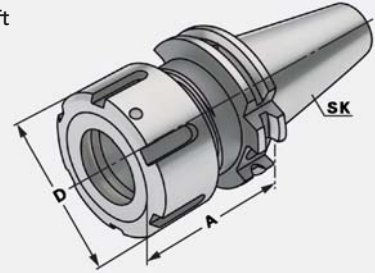

DIN 69871

Form AD/B

$\nearrow \leq 0,003$

G6,3
15.000 min⁻¹

CAD

→ 11.04

Bestell-Nr. Order no. Référence	SK	Spannbereich Capacity Capacité	A	D
302.01.16 *	SK 30	2 – 16 (OZ 16)	60	43
302.01.25 *	SK 30	2 – 25 (OZ 25)	80	60
403.01.16	SK 40	2 – 16 (OZ 16)	70	43
403.01.25	SK 40	2 – 25 (OZ 25)	70	60
403.01.32	SK 40	3 – 32 (OZ 32)	90	72
403.01.16.1	SK 40	2 – 16 (OZ 16)	100	43
403.01.25.1	SK 40	2 – 25 (OZ 25)	100	60
503.01.25	SK 50	2 – 25 (OZ 25)	70	60
503.01.32	SK 50	3 – 32 (OZ 32)	80	72
503.01.32.1	SK 50	3 – 32 (OZ 32)	100	72

* DIN 69871 Form AD
* DIN 69871 form AD
* DIN 69871 forme AD

Lieferumfang: Mit kugellagerter Spannmutter
Delivery: With ball bearing clamping nut
Livraison: Avec écrou de serrage à roulement à billes



Spannfutter für Spannzangen DIN 6499 (ISO 15488) System ER

DIN 69871



Collet chucks for collets DIN 6499 (ISO 15488) ER-system
Mandrins à pinces pour pinces DIN 6499 (ISO 15488) système ER



Verwendung:
Zur Aufnahme von Werkzeugen mit Zylinderschaft in Spannzangen.

Application:
For mounting straight-shank tools in collets.

Application:
Pour le serrage d'outils avec queue cylindrique dans des pinces de serrage.

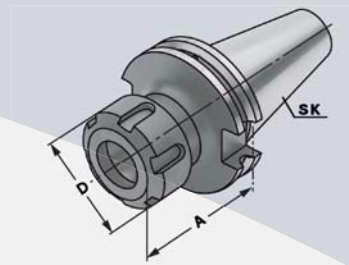

DIN 69871

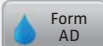

CAD



Bestell-Nr. Order no. Référence	SK	Spannbereich Capacity Capacité	A	D
302.02.10	SK 30	1 – 10 (ER 16)	70	32
302.02.16	SK 30	2 – 16 (ER 25)	70	42
302.02.20	SK 30	2 – 20 (ER 32)	70	50
302.02.26	SK 30	3 – 26 (ER 40)	70	63
302.02.10.1	SK 30	1 – 10 (ER 16)	100	32
302.02.16.1	SK 30	2 – 16 (ER 25)	100	42
302.02.20.1	SK 30	2 – 20 (ER 32)	100	50
402.02.10	SK 40	1 – 10 (ER 16)	63	32
402.02.16	SK 40	2 – 16 (ER 25)	60	42
402.02.20	SK 40	2 – 20 (ER 32)	70	50
402.02.26	SK 40	3 – 26 (ER 40)	80	63
402.02.10.1	SK 40	1 – 10 (ER 16)	100	32
402.02.16.1	SK 40	2 – 16 (ER 25)	100	42
402.02.20.1	SK 40	2 – 20 (ER 32)	100	50
402.02.26.1	SK 40	3 – 26 (ER 40)	100	63

Lieferumfang: Mit gewuchteter Spannmutter
Delivery: With balanced clamping nut
Livraison: Avec écrou de serrage équilibré





Verwendung:

Zur Aufnahme von Werkzeugen mit Zylinderschaft in Spannzangen.

Application:

For mounting straight-shank tools in collets.

Application:

Pour le serrage d'outils avec queue cylindrique dans des pinces de serrage.

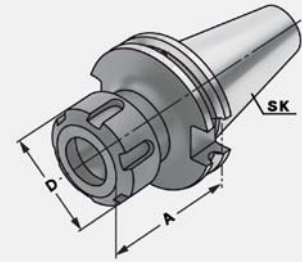

DIN 69871

Form AD/B

$\leq 0,003$

G6,3
15.000 min⁻¹

CAD

→ 11.04

Bestell-Nr. Order no. Référence	SK	Spannbereich Capacity Capacité	A	D
403.02.10	SK 40	1 – 10 (ER 16)	63	32
403.02.16	SK 40	2 – 16 (ER 25)	60	42
403.02.20	SK 40	2 – 20 (ER 32)	70	50
403.02.26	SK 40	3 – 26 (ER 40)	80	63
403.02.10.1	SK 40	1 – 10 (ER 16)	100	32
403.02.16.1	SK 40	2 – 16 (ER 25)	100	42
403.02.20.1	SK 40	2 – 20 (ER 32)	100	50
403.02.26.1	SK 40	3 – 26 (ER 40)	100	63
403.02.10.2	SK 40	1 – 10 (ER 16)	160	32
403.02.16.2	SK 40	2 – 16 (ER 25)	160	42
403.02.20.2	SK 40	2 – 20 (ER 32)	160	50
403.02.26.2	SK 40	3 – 26 (ER 40)	160	63
403.02.10.3	SK 40	1 – 10 (ER 16)	200	32
403.02.16.3	SK 40	2 – 16 (ER 25)	200	42
403.02.20.3	SK 40	2 – 20 (ER 32)	200	50
403.02.26.3	SK 40	3 – 26 (ER 40)	200	63

Lieferumfang: Mit gewuchteter Spannmutter
Delivery: With balanced clamping nut
Livraison: Avec écrou de serrage équilibré



Spannfutter für Spannzangen DIN 6499 (ISO 15488) System ER

DIN 69871



Collet chucks for collets DIN 6499 (ISO 15488) ER-system
Mandrins à pinces pour pinces DIN 6499 (ISO 15488) système ER



Verwendung:
Zur Aufnahme von Werkzeugen mit Zylinderschaft in Spannzangen.

Application:
For mounting straight-shank tools in collets.

Application:
Pour le serrage d'outils avec queue cylindrique dans des pinces de serrage.

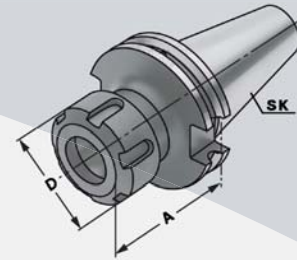

DIN 69871



$\nabla \leq 0,003$

G6,3
15.000 min⁻¹

CAD



Bestell-Nr. Order no. Référence	SK	Spannbereich Capacity Capacité	A	D
503.02.10	SK 50	1 – 10 (ER 16)	70	32
503.02.16	SK 50	2 – 16 (ER 25)	60	42
503.02.20	SK 50	2 – 20 (ER 32)	70	50
503.02.26	SK 50	3 – 26 (ER 40)	80	63
503.02.10.1	SK 50	1 – 10 (ER 16)	100	32
503.02.16.1	SK 50	2 – 16 (ER 25)	100	42
503.02.20.1	SK 50	2 – 20 (ER 32)	100	50
503.02.26.1	SK 50	3 – 26 (ER 40)	100	63
503.02.10.2	SK 50	1 – 10 (ER 16)	160	32
503.02.16.2	SK 50	2 – 16 (ER 25)	160	42
503.02.20.2	SK 50	2 – 20 (ER 32)	160	50
503.02.26.2	SK 50	3 – 26 (ER 40)	160	63
503.02.10.3	SK 50	1 – 10 (ER 16)	200	32
503.02.16.3	SK 50	2 – 16 (ER 25)	200	42
503.02.20.3	SK 50	2 – 20 (ER 32)	200	50
503.02.26.3	SK 50	3 – 26 (ER 40)	200	63

Lieferumfang: Mit gewuchteter Spannmutter
Delivery: With balanced clamping nut
Livraison: Avec écrou de serrage équilibré





Laser engraving
of toolholders

Marquage laser
de porte-outils



Laserbeschriftung von Werkzeugaufnahmen:

Durch unsere Laserbeschriftungsanlagen können wir Ihnen individuelle, kostengünstige Laserbeschriftung der Werkzeuge anbieten. Die dauerhafte Beschriftung kann mit Ihrem Firmennamen, Firmenlogo oder mit sonstigen Sonderzeichen erfolgen.

Laser engraving of toolholders:

With our newly acquired laser engravers we can immediately offer you individual and cost-effective engraving of tools. The permanent engraving can include your company's name, logo or any other special description.

Marquage laser de porte-outils:

A l'aide de notre dispositif de marquage laser nous sommes en mesure de labelliser vos porte-outils avec votre nom, logo ou autres données.

Spannfutter für Spannzangen System KPS

Collet chucks for collets KPS-system

Mandrins à pinces pour pinces système KPS

DIN 69871



Verwendung:

Zur Aufnahme von Werkzeugen mit Zylinderschaft in Spannzangen.
Für Anwendungen im HSC-Bereich und für hochpräzise Bearbeitungsergebnisse.

Application:

For mounting straight-shank tools in collets.
To use for high speed cutting and high precision milling.

Application:

Pour le serrage d'outils avec queue cylindrique dans des pinces de serrage.
Pour l'usage dans le coupage à grande vitesse et dans l'usinage à grande précision.

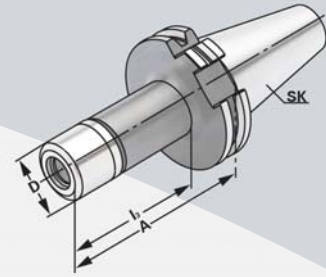

DIN 69871



$\nabla \leq 0,003$

G2,5
30.000 min⁻¹

CAD



Bestell-Nr. Order no. Référence	SK	Spannbereich Capacity Capacité	A	D
302.03.10	SK 30	1 – 10 (KPS 10)	60	27,5
302.03.16	SK 30	4 – 16 (KPS 16)	60	40
302.03.10.1	SK 30	1 – 10 (KPS 10)	90	27,5
302.03.16.1	SK 30	4 – 16 (KPS 16)	90	40
402.03.10	SK 40	1 – 10 (KPS 10)	60	27,5
402.03.16	SK 40	4 – 16 (KPS 16)	60	40
402.03.10.1	SK 40	1 – 10 (KPS 10)	90	27,5
402.03.16.1	SK 40	4 – 16 (KPS 16)	90	40
402.03.10.2	SK 40	1 – 10 (KPS 10)	120	27,5
402.03.16.2	SK 40	4 – 16 (KPS 16)	120	40
502.03.10	SK 50	1 – 10 (KPS 10)	105	27,5
502.03.16	SK 50	4 – 16 (KPS 16)	105	40
502.03.10.1	SK 50	1 – 10 (KPS 10)	135	27,5
502.03.16.1	SK 50	4 – 16 (KPS 16)	135	40
502.03.10.2	SK 50	1 – 10 (KPS 10)	165	27,5
502.03.16.2	SK 50	4 – 16 (KPS 16)	165	40

Lieferumfang: Mit gewuchteter Spannmutter
Delivery: With balanced clamping nut
Livraison: Avec écrou de serrage équilibré





**Spannfutter DIN 6391 für Spannzangen
DIN 6388 (ISO 10897) System OZ – ohne Mitnehmernuten**

DIN 69871

*Collet chucks DIN 6391 for collets DIN 6388 (ISO 10897) OZ-system – without drive slots
Mandrins à pinces DIN 6391 pour pinces DIN 6388 (ISO 10897) système OZ –
sans rainures d'entraînement*



Verwendung:
Zur Aufnahme von Werkzeugen zur Holzbearbeitung mit Zylinderschaft in Spannzangen.

Application:
For mounting straight-shank tools for woodworking in collets.

Application:
Pour le serrage d'outils pour le travail du bois avec queue cylindrique dans des pinces de serrage.

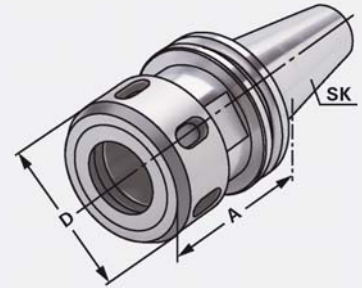

DIN 69871 Form AD $\sqrt{\text{Ra}} \leq 0,003$ G6,3 20.000 min⁻¹ CAD 11.04

Bestell-Nr. Order no. Référence	SK	Spannbereich Capacity Capacité	A	D
302.61.25	SK 30	2 – 25 (OZ 25)	71	60
402.61.25	SK 40	2 – 25 (OZ 25)	63	60

Lieferumfang: Mit kugelgelagerter Spannmutter
Delivery: With ball bearing clamping nut
Livraison: Avec écrou de serrage à roulement à billes



Spannfutter für Spannzangen DIN 6499 (ISO 15488) System ER – ohne Mitnehmernuten

DIN 69871



Collet chucks for collets DIN 6499 (ISO 15488) ER-system – without drive slots

Mandrins à pinces pour pinces DIN 6499 (ISO 15488) système ER – sans rainures d'entraînement



Verwendung:

Zur Aufnahme von Werkzeugen zur Holzbearbeitung mit Zylinderschaft in Spannzangen.

Application:

For mounting straight-shank tools for woodworking in collets.

Application:

Pour le serrage d'outils pour le travail du bois avec queue cylindrique dans des pinces de serrage.

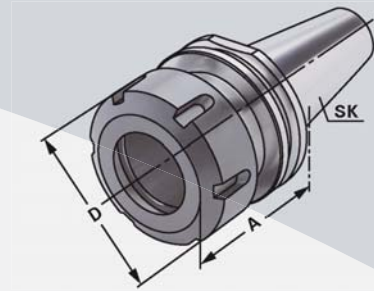

DIN 69871

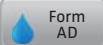

$\nabla \leq 0,003$

G6,3
20.000 min⁻¹

CAD



Bestell-Nr. Order no. Référence	SK	Spannbereich Capacity Capacité	A	D
302.62.16	SK 30	2 – 16 (ER 25)	50	42
302.62.20	SK 30	2 – 20 (ER 32)	50	50
302.62.20.1	SK 30	2 – 20 (ER 32)	57	50
302.62.20.2	SK 30	2 – 20 (ER 32)	63	50
302.62.26	SK 30	3 – 26 (ER 40)	60	63
402.62.16	SK 40	2 – 16 (ER 25)	50	42
402.62.20	SK 40	2 – 20 (ER 32)	50	50
402.62.26	SK 40	3 – 26 (ER 40)	63	63

Lieferumfang: Mit gewuchteter Spannmutter
Delivery: With balanced clamping nut
Livraison: Avec écrou de serrage équilibré





Spannfutter für Spannzangen DIN 6499 (ISO 15488) System ER - Mini

DIN 69871

Collet chucks for collets DIN 6499 (ISO 15488) ER-system - Mini
Mandrins à pinces pour pinces DIN 6499 (ISO 15488) système ER - Mini



Verwendung:
Zur Aufnahme von Werkzeugen mit Zylinderschaft in Spannzangen.

Application:
For mounting straight-shank tools in collets with.

Application:
Pour le serrage d'outils avec queue cylindrique dans des pinces de serrage.

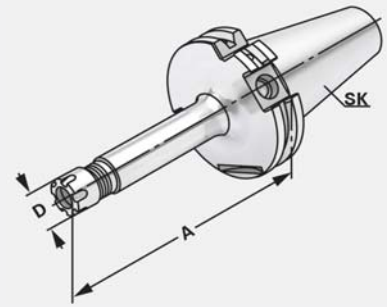

DIN 69871 Form AD/B $\nabla \leq 0,003$ G6,3 15.000 min⁻¹ CAD



Bestell-Nr. Order no. Référence	SK	Spannbereich Capacity Capacité	A	D
403.02.07	SK 40	1 – 7 (ER 11)	55	16
403.02.07.1	SK 40	1 – 7 (ER 11)	100	16
403.02.07.2	SK 40	1 – 7 (ER 11)	160	16
403.02.07.10	SK 40	1 – 10 (ER 16)	55	22
403.02.07.10.1	SK 40	1 – 10 (ER 16)	100	22
403.02.07.10.2	SK 40	1 – 10 (ER 16)	160	22



Hochleistungs-Kraftspannfutter System HKS

High Performance Milling Chuck HKS-system

Mandrin de serrage à haute performance système HKS

DIN 69871



Verwendung:
Zur Aufnahme von Werkzeugen mit Zylinderschaft nach DIN 1835 Form A+B+E und DIN 6535 Form HA+HB+HE (größer Ø 20 mm nur mit Reduzierung).

Application:
For mounting straight-shank tools acc. DIN 1835 form A+B+E and DIN 6535 form HA+HB+HE (larger than dia. 20 mm only with reduction sleeve).

Application:
Pour le serrage d'outils avec queue cylindrique suivant DIN 1835 forme A+B+E et DIN 6535 forme HA+HB+HE (à partir de dia. 20 mm seulement avec réduction).

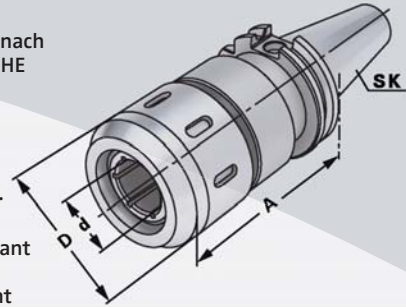

DIN 69871



$\nabla \leq 0,003$

G6,3
15.000 min⁻¹

CAD



Bestell-Nr. Order no. Référence	SK	Spannbereich Capacity Capacité	A	D
403.64.20	SK 40	20 (HKS 20)	90	53
403.64.32	SK 40	32 (HKS 32)	105	68
503.64.20	SK 50	20 (HKS 20)	90	53
503.64.32	SK 50	32 (HKS 32)	90	68



8.45



8.47



Verwendung:

Zum Spannen von zylindrischen Werkzeugschäften mit seitlicher Spannfläche nach DIN 1835 Form B (Weldon).

Application:

For mounting straight-shank tools with flat according to DIN 1835 form B (Weldon).

Application:

Pour le serrage d'outils avec queue cylindrique et avec méplat suivant DIN 1835 forme B (Weldon).

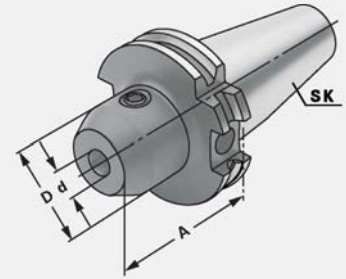

DIN 69871
Form AD
 $\nabla \leq 0,003$
G6,3 15.000 min⁻¹
CAD
11.04

Bestell-Nr. Order no. Référence	SK	d ^{H4}	A	D
302.04.06	SK 30	6	50	25
302.04.08	SK 30	8	50	28
302.04.10	SK 30	10	50	35
302.04.12	SK 30	12	50	42
302.04.14	SK 30	14	63	44
302.04.16	SK 30	16	63	48
302.04.18	SK 30	18	63	50
302.04.20	SK 30	20	70	52
402.04.06	SK 40	6	50	25
402.04.08	SK 40	8	50	28
402.04.10	SK 40	10	50	35
402.04.12	SK 40	12	50	42
402.04.14	SK 40	14	50	44
402.04.16	SK 40	16	63	48
402.04.18	SK 40	18	63	50
402.04.20	SK 40	20	63	52
402.04.25	SK 40	25	100	65
402.04.32	SK 40	32	100	72

Hinweis: Ab d = 25 mit zwei Spannschrauben
Note: From d = 25 on two clamping screws
Observation: A partir de d = 25 avec deux vis de serrage

Lieferumfang: Mit Spannschraube
Delivery: With clamping screw
Livraison: Avec vis de serrage



Fräseraufnahmen DIN 6359 für Zylinderschäfte DIN 1835-B

End mill holders DIN 6359 for end mills DIN 1835-B

Porte-fraises DIN 6359 pour queues cylindriques DIN 1835-B

DIN 69871



Verwendung:

Zum Spannen von zylindrischen Werkzeugschäften mit seitlicher Spannfläche nach DIN 1835 Form B (Weldon).

Application:

For mounting straight-shank tools with flat according to DIN 1835 form B (Weldon).

Application:

Pour le serrage d'outils avec queue cylindrique et avec méplat suivant DIN 1835 forme B (Weldon).

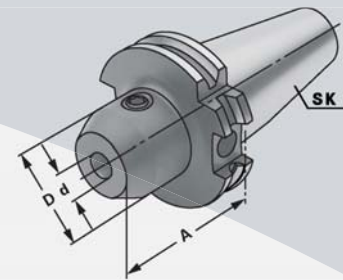

DIN 69871



$\nabla \leq 0,003$

G6,3
15.000 min⁻¹

CAD



Bestell-Nr.
Order no.
Référence

Bestell-Nr. Order no. Référence	SK	d ^{H4}	A	D
403.04.16.0	SK 40	16	35	45
403.04.20.0	SK 40	20	35	45
403.04.25.0	SK 40	25	35	50
403.04.32.0	SK 40	32	65	50
403.04.06	SK 40	6	50	25
403.04.08	SK 40	8	50	28
403.04.10	SK 40	10	50	35
403.04.12	SK 40	12	50	42
403.04.14	SK 40	14	50	44
403.04.16	SK 40	16	63	48
403.04.18	SK 40	18	63	50
403.04.20	SK 40	20	63	52
403.04.25	SK 40	25	100	65
403.04.32	SK 40	32	100	72
403.04.40	SK 40	40	120	80
403.04.06.1	SK 40	6	100	25
403.04.08.1	SK 40	8	100	28
403.04.10.1	SK 40	10	100	35
403.04.12.1	SK 40	12	100	42
403.04.14.1	SK 40	14	100	44
403.04.16.1	SK 40	16	100	48
403.04.18.1	SK 40	18	100	50
403.04.20.1	SK 40	20	100	52
403.04.06.2	SK 40	6	160	25
403.04.08.2	SK 40	8	160	28
403.04.10.2	SK 40	10	160	35
403.04.12.2	SK 40	12	160	42
403.04.14.2	SK 40	14	160	44
403.04.16.2	SK 40	16	160	48
403.04.18.2	SK 40	18	160	50
403.04.20.2	SK 40	20	160	52
403.04.25.2	SK 40	25	160	65
403.04.32.2	SK 40	32	160	72
403.04.40.2	SK 40	40	160	80

Hinweis:

Note:

Observation:

Ab d = 25 mit zwei Spannschrauben

From d = 25 on two clamping screws

A partir de d = 25 avec deux vis de serrage

Lieferumfang:

Delivery:

Livraison:

Mit Spannschraube

With clamping screw

Avec vis de serrage



Verwendung:

Zum Spannen von zylindrischen Werkzeugschäften mit seitlicher Spannfläche nach DIN 1835 Form B (Weldon).

Application:

For mounting straight-shank tools with flat according to DIN 1835 form B (Weldon).

Application:

Pour le serrage d'outils avec queue cylindrique et avec méplat suivant DIN 1835 forme B (Weldon).

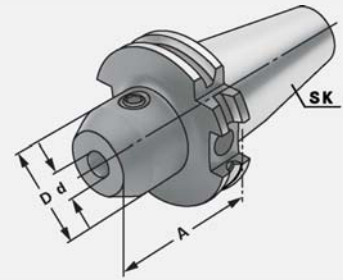

DIN 69871
Form AD/B
 $\nabla \leq 0,003$
G6,3 15.000 min⁻¹
CAD
11.04

Bestell-Nr. Order no. Référence	SK	d ^{H4}	A	D
503.04.06	SK 50	6	63	25
503.04.08	SK 50	8	63	28
503.04.10	SK 50	10	63	35
503.04.12	SK 50	12	63	42
503.04.14	SK 50	14	63	44
503.04.16	SK 50	16	63	48
503.04.18	SK 50	18	63	50
503.04.20	SK 50	20	63	52
503.04.25	SK 50	25	80	65
503.04.32	SK 50	32	100	72
503.04.40	SK 50	40	100	80

Hinweis: Ab d = 25 mit zwei Spannschrauben
Note: From d = 25 on two clamping screws
Observation: A partir de d = 25 avec deux vis de serrage

Lieferumfang: Mit Spannschraube
Delivery: With clamping screw
Livraison: Avec vis de serrage



Fräseraufnahmen DIN 6359 für Zylinderschäfte DIN 1835-B

End mill holders DIN 6359 for end mills DIN 1835-B

Porte-fraises DIN 6359 pour queues cylindriques DIN 1835-B

DIN 69871



Verwendung:

Zum Spannen von zylindrischen Werkzeugschäften mit seitlicher Spannfläche nach DIN 1835 Form B (Weldon).

Application:

For mounting straight-shank tools with flat according to DIN 1835 form B (Weldon).

Application:

Pour le serrage d'outils avec queue cylindrique et avec méplat suivant DIN 1835 forme B (Weldon).

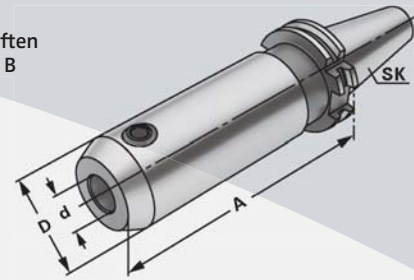

DIN 69871



$\nabla \leq 0,003$

G6,3
15.000 min⁻¹

CAD



Bestell-Nr.
Order no.
Référence

Bestell-Nr. Order no. Référence	SK	d ^{H4}	A	D
503.04.06.1	SK 50	6	100	25
503.04.08.1	SK 50	8	100	28
503.04.10.1	SK 50	10	100	35
503.04.12.1	SK 50	12	100	42
503.04.14.1	SK 50	14	100	44
503.04.16.1	SK 50	16	100	48
503.04.18.1	SK 50	18	100	50
503.04.20.1	SK 50	20	100	52
503.04.25.1	SK 50	25	120	65
503.04.06.2	SK 50	6	160	25
503.04.08.2	SK 50	8	160	28
503.04.10.2	SK 50	10	160	35
503.04.12.2	SK 50	12	160	42
503.04.14.2	SK 50	14	160	44
503.04.16.2	SK 50	16	160	48
503.04.18.2	SK 50	18	160	50
503.04.20.2	SK 50	20	160	52
503.04.25.2	SK 50	25	160	65
503.04.32.2	SK 50	32	160	72
503.04.40.2	SK 50	40	160	80

Hinweis:

Ab d = 25 mit zwei Spannschrauben

Note:

From d = 25 on two clamping screws

Observation:

A partir de d = 25 avec deux vis de serrage

Lieferumfang:

Mit Spannschraube

Delivery:

With clamping screw

Livraison:

Avec vis de serrage



8.61



Verwendung:

Zum Spannen von zylindrischen Werkzeugschäften mit seitlicher Spannfläche nach DIN 1835 Form B (Weldon). Mit Kühlkanälen für optimale Kühlung der Werkzeugschneide.

Application:

For mounting straight-shank tools with flat according to DIN 1835 form B (Weldon). With coolant channels for optimal coolant at the cutting edge.

Application:

Pour le serrage d'outils avec queue cylindrique et avec méplat suivant DIN 1835 forme B (Weldon). Avec canaux d'arrosage pour un refroidissement optimal aux lames.

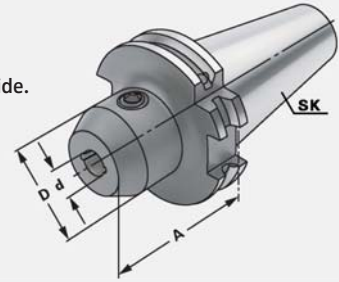

DIN 69871	Form AD/B	$\sqrt{\text{Ra}} \leq 0,003$	G6,3 15.000 min ⁻¹	CAD	11.04
-----------	-----------	-------------------------------	-------------------------------	-----	-------

Bestell-Nr. Order no. Référence	SK	d ^{H4}	A	D
403.04.06.K	SK 40	6	50	25
403.04.08.K	SK 40	8	50	28
403.04.10.K	SK 40	10	50	35
403.04.12.K	SK 40	12	50	42
403.04.14.K	SK 40	14	50	44
403.04.16.K	SK 40	16	63	48
403.04.18.K	SK 40	18	63	50
403.04.20.K	SK 40	20	63	52
403.04.25.K	SK 40	25	100	65
403.04.32.K	SK 40	32	100	72
403.04.40.K	SK 40	40	120	80
403.04.06.1.K	SK 40	6	100	25
403.04.08.1.K	SK 40	8	100	28
403.04.10.1.K	SK 40	10	100	35
403.04.12.1.K	SK 40	12	100	42
403.04.14.1.K	SK 40	14	100	44
403.04.16.1.K	SK 40	16	100	48
403.04.18.1.K	SK 40	18	100	50
403.04.20.1.K	SK 40	20	100	52

Hinweis: Ab d = 25 mit zwei Spannschrauben
d = 6 bis 14 mit zwei Kühlkanälen
d = 16 bis 40 mit vier Kühlkanälen
Für Werkzeuge mit innerer Kühlmittelzufuhr muss ein O-Ring eingesetzt werden.

Note: From d = 25 on two clamping screws
d = 6 to 14 with two coolant channels
d = 16 to 40 with four coolant channels
For tools with through coolant an O-ring must be used.

Observation: A partir de d = 25 avec deux vis de serrage
d = 6 bis 14 avec deux canaux d'arrosage
d = 16 bis 40 avec quatre canaux d'arrosage
Pour outils avec arrosage interne il faut utiliser un joint torique.

Lieferumfang: Mit Spannschraube und O-Ring
Delivery: With clamping screw and O-ring
Livraison: Avec vis de serrage et joint torique



Fräseraufnahmen DIN 6359 mit Kühlkanälen für Zylinderschäfte DIN 1835-B

DIN 69871



End mill holders DIN 6359 with coolant channels for end mills DIN 1835-B

Porte-fraises DIN 6359 avec canaux d'arrosage pour queues cylindriques DIN 1835-B



Verwendung:

Zum Spannen von zylindrischen Werkzeugschäften mit seitlicher Spannfläche nach DIN 1835 Form B (Weldon). Mit Kühlkanälen für optimale Kühlung der Werkzeugschneide.

Application:

For mounting straight-shank tools with flat according to DIN 1835 form B (Weldon).

With coolant channels for optimal coolant at the cutting edge.

Application:

Pour le serrage d'outils avec queue cylindrique et avec méplat suivant DIN 1835 forme B (Weldon). Avec canaux d'arrosage pour un refroidissement optimal aux lames.

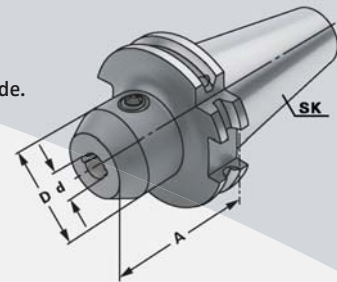

DIN 69871



CAD



Bestell-Nr.
Order no.
Référence

	SK	d ^{H4}	A	D
503.04.06.K	SK 50	6	63	25
503.04.08.K	SK 50	8	63	28
503.04.10.K	SK 50	10	63	35
503.04.12.K	SK 50	12	63	42
503.04.14.K	SK 50	14	63	44
503.04.16.K	SK 50	16	63	48
503.04.18.K	SK 50	18	63	50
503.04.20.K	SK 50	20	63	52
503.04.25.K	SK 50	25	80	65
503.04.32.K	SK 50	32	100	72
503.04.40.K	SK 50	40	100	80
503.04.06.1.K	SK 50	6	100	25
503.04.08.1.K	SK 50	8	100	28
503.04.10.1.K	SK 50	10	100	35
503.04.12.1.K	SK 50	12	100	42
503.04.14.1.K	SK 50	14	100	44
503.04.16.1.K	SK 50	16	100	48
503.04.18.1.K	SK 50	18	100	50
503.04.20.1.K	SK 50	20	100	52

Hinweis:

Ab d = 25 mit zwei Spanschrauben

d = 6 bis 14 mit zwei Kühlkanälen

d = 16 bis 40 mit vier Kühlkanälen

Für Werkzeuge mit innerer Kühlmittelzufuhr muss ein O-Ring eingesetzt werden.

Note:

From d = 25 on two clamping screws

d = 6 to 14 with two coolant channels

d = 16 to 40 with four coolant channels

For tools with through coolant an O-ring must be used.

Observation:

A partir de d = 25 avec deux vis de serrage

d = 6 bis 14 avec deux canaux d'arrosage

d = 16 bis 40 avec quatre canaux d'arrosage

Pour outils avec arrosage interne il faut utiliser un joint torique.



Lieferumfang:

Mit Spanschraube und O-Ring

Delivery:

With clamping screw and O-ring

Livraison:

Avec vis de serrage et joint torique





Verwendung:

Zum Spannen von zylindrischen Werkzeugschäften mit geneigter Spannfläche nach DIN 1835 Form E (Whistle Notch).

Application:

For mounting straight-shank tools and inclined flat according to DIN 1835 form E (Whistle Notch).

Application:

Pour le serrage d'outils avec queue cylindrique et avec méplat incliné suivant DIN 1835 forme E (Whistle Notch).

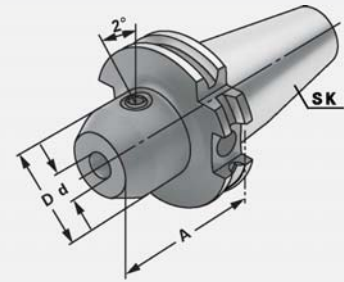

DIN 69871
Form AD/B
 $\nabla \leq 0,003$
G6,3 15.000 min⁻¹
CAD
11.04

Bestell-Nr. Order no. Référence	SK	d ^{H4}	A	D
403.05.06	SK 40	6	50	25
403.05.08	SK 40	8	50	28
403.05.10	SK 40	10	50	35
403.05.12	SK 40	12	50	42
403.05.14	SK 40	14	50	44
403.05.16	SK 40	16	63	48
403.05.18	SK 40	18	63	50
403.05.20	SK 40	20	63	52
403.05.25	SK 40	25	100	65
403.05.32	SK 40	32	100	72
403.05.40	SK 40	40	120	80
503.05.06	SK 50	6	63	25
503.05.08	SK 50	8	63	28
503.05.10	SK 50	10	63	35
503.05.12	SK 50	12	63	42
503.05.14	SK 50	14	63	44
503.05.16	SK 50	16	63	48
503.05.18	SK 50	18	63	50
503.05.20	SK 50	20	63	52
503.05.25	SK 50	25	80	65
503.05.32	SK 50	32	100	72
503.05.40	SK 50	40	100	80

Hinweis: Ab d = 25 mit zwei Spannschrauben
Note: From d = 25 on two clamping screws
Observation: A partir de d = 25 avec deux vis de serrage

Lieferumfang: Mit Spannschraube und axialer Verstellechraube
Delivery: With clamping screw and axial adjustment bolt
Livraison: Avec vis de serrage et vis de butée axiale



Zwischenhülsen für MK mit Austreibblappen DIN 6383

Adaptor sleeves for MT with tang DIN 6383

Douilles de réduction pour CM à tenon DIN 6383

DIN 69871



Verwendung:

Zur Aufnahme von Werkzeugen mit Morsekegelschaft und Austreibblappen nach DIN 228-1 Form B.

Application:

For mounting tools with Morse taper shank and tang according to DIN 228-1 form B.

Application:

Pour le serrage d'outils avec queue cône Morse et tenon suivant DIN 228-1 forme B.

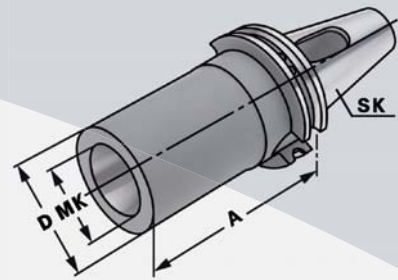

DIN 69871



$\nabla \leq 0,005$

G6,3
15.000 min⁻¹

CAD

Bestell-Nr.
Order no.
Référence

Bestell-Nr. Order no. Référence	SK	MK	A	D
302.07.01 *	SK 30	1	50	25
302.07.02 *	SK 30	2	65	32
302.07.03 *	SK 30	3	80	40
402.07.01 *	SK 40	1	50	25
402.07.02 *	SK 40	2	50	32
402.07.03 *	SK 40	3	70	40
402.07.04 *	SK 40	4	95	48
403.07.01	SK 40	1	50	25
403.07.02	SK 40	2	50	32
403.07.03	SK 40	3	70	40
403.07.04	SK 40	4	95	48
402.07.02.1 *	SK 40	2	117	32
402.07.03.1 *	SK 40	3	133	40
402.07.04.1 *	SK 40	4	156	48
503.07.01	SK 50	1	45	25
503.07.02	SK 50	2	60	32
503.07.03	SK 50	3	65	40
503.07.04	SK 50	4	95	48
503.07.05	SK 50	5	105	63
502.07.02.1 *	SK 50	2	117	32
502.07.03.1 *	SK 50	3	137	40
502.07.04.1 *	SK 50	4	167	48
502.07.05.1 *	SK 50	5	197	63

* DIN 69871 Form AD

* DIN 69871 form AD

* DIN 69871 forme AD





Verwendung:

Zum Spannen von Werkzeugen mit Morsekegelschaft und Anzugsgewinde nach DIN 228-1 Form A.

Application:

For clamping tools with Morse taper shank and thread according to DIN 228-1 form A.

Application:

Pour le serrage d'outils avec queue cône Morse et filetage suivant DIN 228-1 forme A.

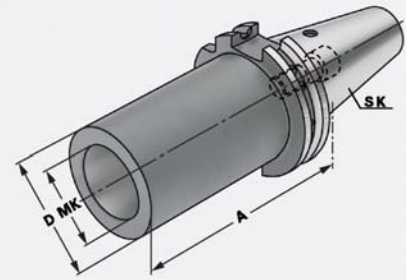

DIN 69871

Form A

$\nabla \leq 0,005$

G6,3
15.000 min⁻¹

CAD

Bestell-Nr.
Order no.
Référence

	SK	MK	M	A	D
402.08.01	SK 40	1	M6	50	25
402.08.02	SK 40	2	M10	50	32
402.08.03	SK 40	3	M12	70	40
402.08.04	SK 40	4	M16	95	48
402.08.04 A *	SK 40	4	M16	110	63
502.08.01	SK 50	1	M6	45	25
502.08.02	SK 50	2	M10	60	32
502.08.03	SK 50	3	M12	65	40
502.08.04	SK 50	4	M16	70	48
502.08.04 A *	SK 50	4	M16	85	63
502.08.05	SK 50	5	M20	100	63
502.08.05 A *	SK 50	5	M20	118	78

* Mit Mitnahmeausfräsung nach DIN 2201

* With drive flats according to DIN 2201

* Avec des fraises d'entraînement suivant DIN 2201

Ausführung: DIN 69871 Form A
Version: DIN 69871 form A
Version: DIN 69871 forme A

Lieferumfang: Mit eingebauter Fräseranzugsschraube
Delivery: With built-in tightening bolt
Livraison: Avec vis de serrage montée



Zwischenhülsen für SK-Aufnahmen

Adaptor sleeves for ISO-toolholders

Douilles de réduction pour porte-outils ISO/SA

DIN 69871



Verwendung:

Zur Aufnahme von Steilkegeln nach DIN 69871, JIS B 6339 und DIN 2080.

Application:

For mounting tapers according to DIN 69871, JIS B 6339 and DIN 2080.

Application:

Pour le serrage de cônes suivant DIN 69871, JIS B 6339 et DIN 2080.

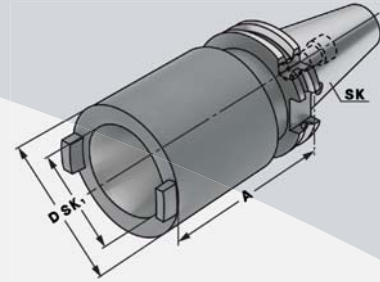

DIN 69871

Form
A

$\nabla \leq 0,005$

G6,3
15.000 min⁻¹

CAD

Bestell-Nr.
Order no.
Référence

	SK	SK ₁	A	D
402.09.30	SK 40	SK 30	50	50
402.09.40	SK 40	SK 40	100	63
502.09.40	SK 50	SK 40	70	70
502.09.50	SK 50	SK 50	120	97

Hinweis:

Lieferung erfolgt mit eingebauter Schraube für Werkzeuge mit gekürztem Steilkegel.
Schraube für DIN 2080 Werkzeuge beiliegend.

Note:

Delivered with a built-in screw for shortened taper tools. Additional screw for DIN 2080 tools included.

Observation:

Livraison avec un vis incorporée pour outils à cône court. Vis pour cônes DIN 2080 incluse.



8.61



Verwendung:
Zur Aufnahme von Walzen-, Walzenstirnfräsern oder Messerköpfen mit Längs- oder Quernut.

Application:
For mounting milling cutters with transverse or longitudinal groove.

Application:
Pour le serrage de fraises à rainure transversale ou à rainure longitudinale.

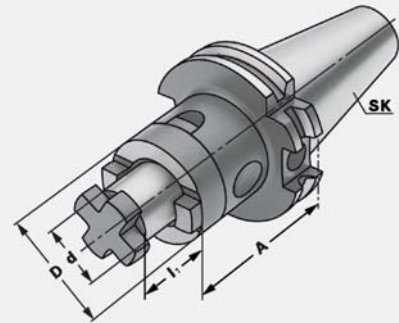

DIN 69871

Form AD/B

$\sqrt{\leq 0,005}$

G6,3
15.000 min⁻¹

CAD

Bestell-Nr. Order no. Référence	SK	d _{h6}	A	l ₁	D
302.10.16 *	SK 30	16	50	17	32
302.10.22 *	SK 30	22	50	19	40
302.10.27 *	SK 30	27	55	21	48
302.10.32 *	SK 30	32	60	24	58
403.10.16	SK 40	16	55	17	32
403.10.22	SK 40	22	55	19	40
403.10.27	SK 40	27	55	21	48
403.10.32	SK 40	32	60	24	58
403.10.40	SK 40	40	60	27	70
403.10.16.1	SK 40	16	100	17	32
403.10.22.1	SK 40	22	100	19	40
403.10.27.1	SK 40	27	100	21	48
403.10.32.1	SK 40	32	100	24	58
403.10.40.1	SK 40	40	100	27	70
403.10.16.2	SK 40	16	160	17	32
403.10.22.2	SK 40	22	160	19	40
403.10.27.2	SK 40	27	160	21	48
403.10.32.2	SK 40	32	160	24	58
403.10.40.2	SK 40	40	160	27	70

* DIN 69871 Form AD
* DIN 69871 form AD
* DIN 69871 forme AD

Lieferumfang: Mit Fräseranzugsschraube, Mitnehmerring und Passfeder
Delivery: With retaining screw, driving ring and feather key
Livraison: Avec vis de serrage, bague d'entraînement et clavette



Kombi-Aufsteckfräserdorne DIN 6358

Combi shell mill holders DIN 6358

Porte-fraises à double usage DIN 6358

DIN 69871



Verwendung:

Zur Aufnahme von Walzen-, Walzenstirnfräsern oder Messerköpfen mit Längs- oder Quernut.

Application:

For mounting milling cutters with transverse or longitudinal groove.

Application:

Pour le serrage de fraises à rainure transversale ou à rainure longitudinale.

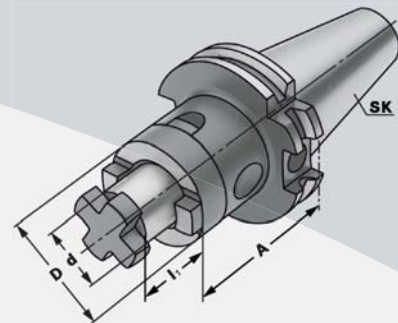

DIN 69871



$\nabla \leq 0,005$

G6,3
15.000 min⁻¹

CAD

Bestell-Nr.
Order no.
Référence

Bestell-Nr. Order no. Référence	SK	d _{h6}	A	l ₁	D
503.10.16	SK 50	16	55	17	32
503.10.22	SK 50	22	55	19	40
503.10.27	SK 50	27	55	21	48
503.10.32	SK 50	32	55	24	58
503.10.40	SK 50	40	55	27	70
503.10.16.1	SK 50	16	100	17	32
503.10.22.1	SK 50	22	100	19	40
503.10.27.1	SK 50	27	100	21	48
503.10.32.1	SK 50	32	100	24	58
503.10.40.1	SK 50	40	100	27	70
503.10.16.2	SK 50	16	160	17	32
503.10.22.2	SK 50	22	160	19	40
503.10.27.2	SK 50	27	160	21	48
503.10.32.2	SK 50	32	160	24	58
503.10.40.2	SK 50	40	160	27	70

Lieferumfang:

Delivery:

Livraison:

Mit Fräseranzugsschraube, Mitnehmerring und Passfeder

With retaining screw, driving ring and feather key

Avec vis de serrage, bague d'entraînement et clavette



Quernut-Aufsteckfräserdorne DIN 6357 mit vergrößerter Anlagefläche und Kühlkanalbohrungen an der Stirnseite

DIN 69871

Shell mill holders DIN 6357 with enlarged contact face and coolant exit bores on the end face

Porte-fraises à trou lisse DIN 6357 avec face de contact élargie et conduits pour l'arrosage frontal



Verwendung:

Zur Aufnahme von Messerköpfen und Fräsern mit Quernut.

Application:

For mounting milling cutters with transversal groove.

Application:

Pour le serrage de fraises à rainure transversale.

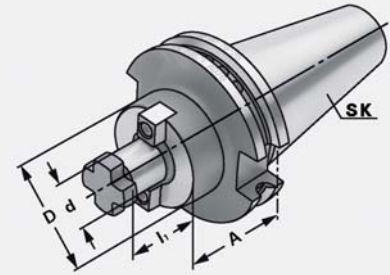

DIN 69871



$\nabla \leq 0,005$

G6,3
15.000 min⁻¹

CAD

Bestell-Nr.
Order no.
Référence

	SK	d _{H6}	A	l ₁	D
302.11.16 *	SK 30	16	40	17	38
302.11.22 *	SK 30	22	40	19	48
302.11.27 *	SK 30	27	50	21	58
302.11.32 *	SK 30	32	50	24	78
402.11.16 *	SK 40	16	35	17	38
402.11.22 *	SK 40	22	35	19	48
402.11.27 *	SK 40	27	40	21	58
402.11.32 *	SK 40	32	50	24	78
402.11.40 *	SK 40	40	50	27	88
403.11.16	SK 40	16	35	17	38
403.11.22	SK 40	22	35	19	48
403.11.27	SK 40	27	40	21	58
403.11.32	SK 40	32	50	24	78
403.11.40	SK 40	40	50	27	88
403.11.16.1	SK 40	16	100	17	38
403.11.22.1	SK 40	22	100	19	48
403.11.27.1	SK 40	27	100	21	58
403.11.32.1	SK 40	32	100	24	78
403.11.40.1	SK 40	40	100	27	88
403.11.16.2	SK 40	16	160	17	38
403.11.22.2	SK 40	22	160	19	48
403.11.27.2	SK 40	27	160	21	58
403.11.32.2	SK 40	32	160	24	78
403.11.40.2	SK 40	40	160	27	88

* DIN 69871 Form AD
* DIN 69871 form AD
* DIN 69871 forme AD

SK 30 ohne Kühlkanalbohrungen an der Stirnseite
SK 30 without coolant exit bores on the end face
SK 30 sans alésages pour l'arrosage frontal

d = 40/d = 60: Für große Planfräser mit vier zusätzlichen Gewindebohrungen nach DIN 2079.
For large diameter face mill cutters with four additional threaded holes according to DIN 2079.
Pour fraises à surfacer à grands diamètres avec quatre trous taraudés additionnels suivant DIN 2079.

Lieferumfang: Mit Mitnehmersteinen, Kreuzschraube und Zylinderkopfschraube nach DIN 912 für Fräser mit innerer Kühlmittelzufuhr. Bei d = 60 nur mit vier Befestigungsschrauben nach DIN 912.

Delivery: With drivers, cross head retaining screw and cylinder head retaining screw for cutters with central coolant. For d = 60 only with four fixation screws according to DIN 912.

Livraison: Avec tenons, une vis cruciforme et une vis à tête cylindrique suivant DIN 912 pour fraises avec arrosage central. Pour d = 60 seulement avec quatre vis de fixation suivant DIN 912.

Quernut-Aufsteckfräserdorne DIN 6357 mit vergrößerter Anlagefläche und Kühlkanalbohrungen an der Stirnseite

DIN 69871



Shell mill holders DIN 6357 with enlarged contact face and coolant exit bores on the end face

Porte-fraises à trou lisse DIN 6357 avec face de contact élargie et conduits pour l'arrosage frontal



Verwendung:

Zur Aufnahme von Messerköpfen und Fräsern mit Quernut.

Application:

For mounting milling cutters with transversal groove.

Application:

Pour le serrage de fraises à rainure transversale.

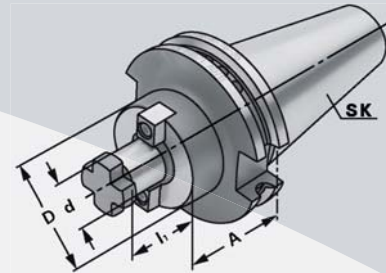

DIN 69871



$\nabla \leq 0,005$

G6,3
15.000 min⁻¹

CAD

Bestell-Nr.
Order no.
Référence

	SK	d _{H6}	A	l ₁	D
503.11.22	SK 50	22	35	19	48
503.11.27	SK 50	27	40	21	58
503.11.32	SK 50	32	50	24	78
503.11.40	SK 50	40	50	27	88
503.11.60	SK 50	60	70	40	129
503.11.22.1	SK 50	22	100	19	48
503.11.27.1	SK 50	27	100	21	58
503.11.32.1	SK 50	32	100	24	78
503.11.40.1	SK 50	40	100	27	88
503.11.22.2	SK 50	22	160	19	48
503.11.27.2	SK 50	27	160	21	58
503.11.32.2	SK 50	32	160	24	78
503.11.40.2	SK 50	40	160	27	88

d = 40/d = 60:

Für große Planfräser mit vier zusätzlichen Gewindebohrungen nach DIN 2079.
For large diameter face mill cutters with four additional threaded holes according to DIN 2079.
Pour fraises à surfer à grands diamètres avec quatre trous taraudés additionnels suivant DIN 2079.

Lieferumfang:

Mit Mitnehmersteinen, Kreuzschraube und Zylinderkopfschraube nach DIN 912 für Fräser mit innerer Kühlmittelzufuhr.

Bei d = 60 nur mit vier Befestigungsschrauben nach DIN 912.

Delivery:

With drivers, cross head retaining screw and cylinder head retaining screw for cutters with central coolant.

For d = 60 only with four fixation screws according to DIN 912.

Livraison:

Avec tenons, une vis cruciforme et une vis à tête cylindrique suivant DIN 912 pour fraises avec arrosage central.

Pour d = 60 seulement avec quatre vis de fixation suivant DIN 912.



8.87



8.85



8.61



Verwendung:

Zur Aufnahme von allen nach DIN 6595 genormten Vollbohrern mit Zylinderschaft.

Application:

For mounting solid drills with cylindrical shank according to DIN 6595.

Application:

Pour le serrage de forets à queue cylindrique suivant DIN 6595.

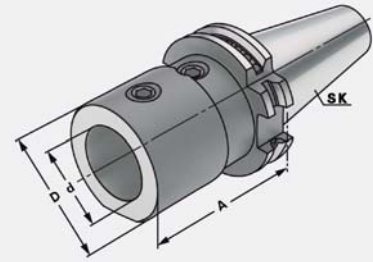

DIN 69871
Form AD/B
 $\nabla \leq 0,005$
G6,3 15.000 min⁻¹
CAD

Bestell-Nr. Order no. Référence	SK	d ^{H5}	A	D
403.51.20	SK 40	20	65	40
403.51.25	SK 40	25	70	45
403.51.32	SK 40	32	75	52
503.51.20	SK 50	20	70	40
503.51.25	SK 50	25	70	45
503.51.32	SK 50	32	70	52
503.51.40	SK 50	40	80	60

Hinweis: Plangeschliffene Anlagefläche
Note: Contact surface precision grinded
Observation: Surface de montage rectifié précisément

Lieferumfang: Mit Spannschrauben
Delivery: With clamping screws
Livraison: Avec vis de serrage



Bohrfutteraufnahmen DIN 238

Drill chuck adaptors DIN 238

Arbres pour mandrins de perçage DIN 238

DIN 69871



Verwendung:
Zur Aufnahme von Bohrfuttern.

Application:
For mounting drill chucks.

Application:
Pour le serrage de mandrins de perçage.

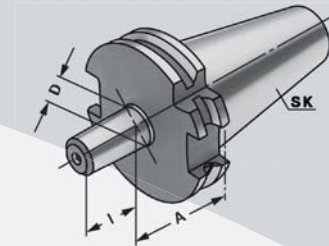

DIN 69871

Form
A

$\nabla \leq 0,005$

G6,3
15.000 min⁻¹

CAD

Bestell-Nr.
Order no.
Référence

	SK	D	A	I
302.14.12	SK 30	B12	25	18,5
302.14.16	SK 30	B16	25	24
402.14.12	SK 40	B12	25	18,5
402.14.16	SK 40	B16	25	24
402.14.18	SK 40	B18	35	32
502.14.12	SK 50	B12	25	18,5
502.14.16	SK 50	B16	25	24
502.14.18	SK 50	B18	25	32



8.103



8.61



Verwendung:
 Zur Aufnahme von Werkzeugen mit Zylinderschaft.

Application:
 For mounting tools with straight shanks.

Application:
 Pour le serrage d'outils avec queue cylindrique.

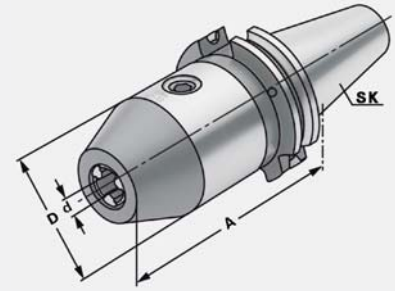

DIN 69871
Form AD
 $\nabla \leq 0,030$
G6,3 15.000 min⁻¹
CAD
11.04

Bestell-Nr. Order no. Référence	SK	Spannbereich Capacity Capacité	A	D
		d		
302.15.08	SK 30	0 – 8	70	36
302.15.13	SK 30	1,0 – 13	111	50
302.15.16	SK 30	2,5 – 16	116	50
402.15.08	SK 40	0 – 8	70	36
402.15.13	SK 40	1,0 – 13	90	50
402.15.16	SK 40	2,5 – 16	95	50
502.15.13	SK 50	1,0 – 13	90	50
502.15.16	SK 50	2,5 – 16	95	50

Hinweis: Hohe Präzision und Rundlaufgenauigkeit von $\leq 0,03$ mm. Sichere Spannung des Werkzeuges durch mechanische Spannkraftverstärkung. Kein selbständiges Lösen der Spannung während der Bearbeitung bei Links- oder Rechtslauf, sowie bei Spindelstop. Spannen und Lösen mit Sechskantschlüssel.

Note: High precision and accurate concentricity of ≤ 0.03 mm. Secure gripping of the tool through mechanical amplification of the clamping force. No automatic slackening of the clamping force while machining with either clockwise or counter clockwise rotation or on spindle stop. Clamping and releasing effected by means of an Allen wrench.

Observation: Précision élevée et exactitude de circularité de $\leq 0,03$ mm. Serrage sûr de l'outil grâce à l'amplification de la force de serrage. Pas de desserrage intempestif en cours d'usinage lors de la rotation la gauche ou la droite, de même qu'en cas d'arrêt de la broche. Serrage et desserrage en utilisant un clé sur à fourche.

Lieferumfang: Mit Spannschlüssel
Delivery: With wrench
Livraison: Avec clé de serrage



CNC-Bohrfutter für Rechts- und Linkslauf

CNC-Drill chucks for clockwise and counter clockwise rotation

Mandrins de perçage CNC pour rotation gauche-droite

DIN 69871



Verwendung:
Zur Aufnahme von Werkzeugen mit
Zylinderschaft.

Application:
For mounting tools with straight shanks.

Application:
Pour le serrage d'outils avec queue
cylindrique.

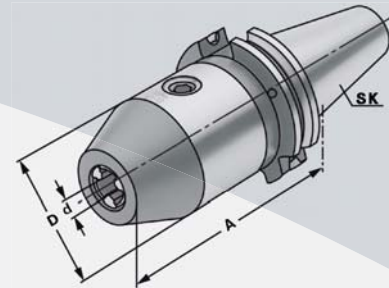

DIN 69871



$\nabla \leq 0,030$

G6,3
15.000 min⁻¹

CAD



Bestell-Nr. Order no. Référence	SK	Spannbereich Capacity Capacité d	A	D
403.15.08	SK 40	0 – 8	70	36
403.15.13	SK 40	1,0 – 13	90	50
403.15.16	SK 40	2,5 – 16	95	50
503.15.13	SK 50	1,0 – 13	90	50
503.15.16	SK 50	2,5 – 16	95	50

Hinweis: Hohe Präzision und Rundlaufgenauigkeit von $\leq 0,03$ mm. Sichere Spannung des Werkzeuges durch mechanische Spannkraftverstärkung. Kein selbständiges Lösen der Spannung während der Bearbeitung bei Links- oder Rechtslauf, sowie bei Spindelstop. Spannen und Lösen mit Sechskantschlüssel.

Note: High precision and accurate concentricity of ≤ 0.03 mm. Secure gripping of the tool through mechanical amplification of the clamping force. No automatic slackening of the clamping force while machining with either clockwise or counter clockwise rotation or on spindle stop. Clamping and releasing effected by means of an Allen wrench.

Observation: Précision élevée et exactitude de circularité de $\leq 0,03$ mm. Serrage sûr de l'outil grâce à l'amplification de la force de serrage. Pas de desserrage intempestif en cours d'usinage lors de la rotation la gauche ou la droite, de même qu'en cas d'arrêt de la broche. Serrage et desserrage en utilisant un clé sur à fourche.

Lieferumfang: Mit Spannschlüssel
Delivery: With wrench
Livraison: Avec clé de serrage



8.61

Gewindeschneid-Schnellwechselfutter mit Längenausgleich auf Druck und Zug

DIN 69871

Quick change tapping chucks *with* length compensation on compression and expansion

Mandrins de taraudage à changement rapide *avec* compensation longitudinale à la compression et traction



Verwendung:

Zur Aufnahme von Schnellwechsel-Einsätzen für Gewindebohrer.

Application:

For the chucking of quick change adaptors for taps.

Application:

Pour le serrage d'adaptateurs porte-tarauts à changement rapide.

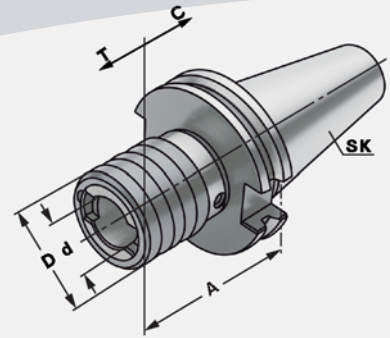

DIN 69871

Form
A

G6,3
15.000 min⁻¹

CAD



Bestell-Nr. Order no. Référence	SK	Spannbereich Capacity Capacité	Größe Size Taille	A	D	d	T	C
302.16.12	SK 30	M3 – M14	1	65	38	19	7	7
302.16.20	SK 30	M5 – M22	2	99	54	31	12	12
402.16.12	SK 40	M3 – M14	1	59	38	19	7	7
402.16.20	SK 40	M5 – M22	2	97	54	31	12	12
402.16.36	SK 40	M14 – M36	3	156	78	48	17,5	17,5
502.16.12	SK 50	M3 – M14	1	63	38	19	7	7
502.16.20	SK 50	M5 – M22	2	97	54	31	12	12
502.16.36	SK 50	M14 – M36	3	140	78	48	17,5	17,5

Hinweis:

Note:

Observation:

Für Bearbeitungszentren ohne Synchronspindel.

For machining centres without synchronous spindle.

Pour centres d'usinage sans broche synchrone.



Gewindeschneid-Schnellwechselfutter ohne Längenausgleich auf Druck und Zug

DIN 69871



Quick-change tapping chucks **without** length compensation on compression and expansion

Mandrins de taraudage à changement rapide **sans** compensation longitudinale à la compression et traction



Verwendung:
Zur Aufnahme von Schnellwechsel-Einsätzen für Gewindebohrer.

Application:
For the chucking of quick change adaptors for taps.

Application:
Pour le serrage d'adaptateurs porte-tarauts à changement rapide.

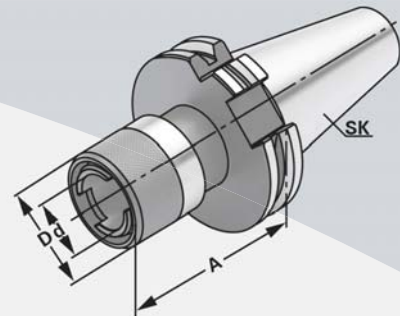

DIN 69871



G6,3
15.000 min⁻¹

CAD



Bestell-Nr. Order no. Référence	SK	Spannbereich Capacity Capacité	Größe Size Taille	A	D	d
302.16.12.1	SK 30	M3 – M14	1	58	38	19
302.16.20.1	SK 30	M5 – M22	2	103	54	31
402.16.12.1	SK 40	M3 – M14	1	62	38	19
402.16.20.1	SK 40	M5 – M22	2	95	54	31
402.16.36.1	SK 40	M14 – M36	3	130	78	48
502.16.12.1	SK 50	M3 – M14	1	60	38	19
502.16.20.1	SK 50	M5 – M22	2	85	54	31
502.16.36.1	SK 50	M14 – M36	3	117	78	48

Hinweis: Für Bearbeitungszentren mit Synchronspindel.
Note: For machining centres with synchronous spindle.
Observation: Pour centres d'usinage avec broche synchrone.



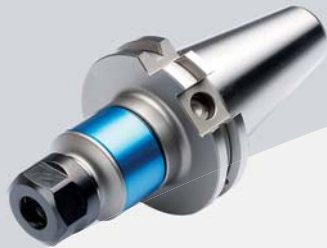

Verwendung:
Für Bearbeitungszentren mit Synchronspindel.

Application:
For machining centres with synchronous spindle.

Application:
Pour centres d'usinage avec broche synchrone.

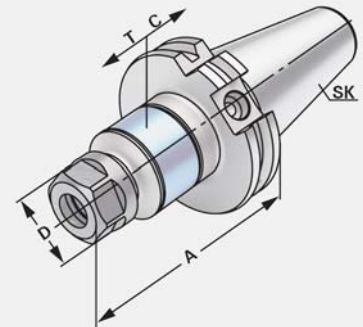

DIN 69871

Form AD/B

G6,3
15.000 min⁻¹

CAD



Bestell-Nr. Order no. Référence	SK	Spannbereich Capacity Capacité	A	D	T	C
302.16.02.10 *	SK 30	M3 – M16 (ER 20)	85	34	0,5	0,5
403.16.02.10	SK 40	M3 – M12 (ER 16)	79	28	0,5	0,5
403.16.02.10.M	SK 40	M3 – M12 (ER 16) Mini	79	22	0,5	0,5
403.16.02.13	SK 40	M3 – M16 (ER 20)	80	34	0,5	0,5
403.16.02.16	SK 40	M3 – M20 (ER 25)	84	42	0,5	0,5
403.16.02.20	SK 40	M3 – M27 (ER 32)	95	50	0,5	0,5
403.16.02.26	SK 40	M3 – M33 (ER 40)	120	63	0,5	0,5
503.16.02.10	SK 50	M3 – M12 (ER 16)	79	28	0,5	0,5
503.16.02.10.M	SK 50	M3 – M12 (ER 16) Mini	79	22	0,5	0,5
503.16.02.10.1.M	SK 50	M3 – M12 (ER 16) Mini	90	22	0,5	0,5
503.16.02.13	SK 50	M3 – M16 (ER 20)	80	34	0,5	0,5
503.16.02.16	SK 50	M3 – M20 (ER 25)	84	42	0,5	0,5
503.16.02.20	SK 50	M3 – M27 (ER 32)	95	50	0,5	0,5
503.16.02.26	SK 50	M3 – M33 (ER 40)	105	63	0,5	0,5

- Hinweis:**
- Synchro-Gewindeschneidfutter kompensieren Synchronisationsfehler.
 - Minimallängenausgleich in Druck- und Zugrichtung zwischen Synchronspindel und Gewindebohrer reduziert zu hohe Gewindeflankenreibungskräfte.
 - Reduziert eventuelle Axialkraftehöhung während des Schneidzyklus auf ein Minimum.
 - Geeignet für Innenkühlung.
 - Kühlmitteldruck max. 100 bar.
- Note:**
- Synchro tapping chucks compensate synchronisation errors.
 - Minimal length compensation on compression and expansion balances very small pitch differences between synchro spindle and tap, which can cause high frictional forces on the thread flanks.
 - A possible increase of axial force during the tapping process is reduced to a minimum.
 - Suitable for internal coolant.
 - Coolant pressure up to max. 100 bar.
- Observation:**
- Mandrins de taraudage version „synchro“ compensent les erreurs éventuelles de synchronisation.
 - Compensation longitudinale minimale à la compression et traction entre la broche synchronisée et le taraud réduit la friction au niveau des flancs de filets.
 - Réduit au minimum les efforts éventuelles axiaux lors du cycle de taraudage.
 - Approprié pour la lubrification centrale.
 - Pression de lubrification max. 100 bar.

Lieferumfang: Mit gewuchteter Spannmutter
Delivery: With balanced clamping nut
Livraison: Avec écrou de serrage équilibré

* DIN 69871 Form AD
 * DIN 69871 form AD
 * DIN 69871 forme AD



Bohrstangenrohlinge

Boring bar blanks
Barres d'alésage

DIN 69871



Verwendung:
Zur Herstellung von Sonderwerkzeugen.

Application:
For the manufacturing of special tools.

Application:
Pour la fabrication d'outils spéciaux.

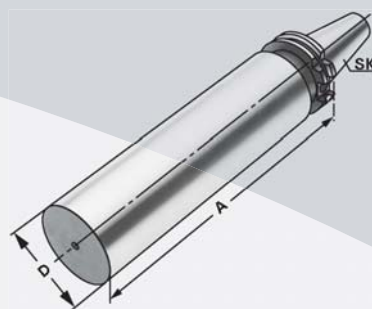

DIN 69871

Form
A

CAD

Bestell-Nr.
Order no.
Référence

SK

D

A

302.17.40

SK 30

40,5

160

402.17.63

SK 40

63

250

502.17.97

SK 50

97

315

Ausführung:

Steilkegel und Bund gehärtet und geschliffen. Schaft weich zur weiteren Bearbeitung.

Version:

Cone and flange hardened and grinded. Soft body for later processing.

Version:

Cône et collerette durcis et rectifiés. Corps doux pour un usinage ultérieur.



8.61

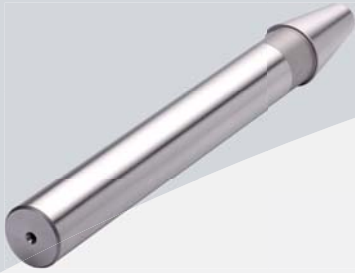

Verwendung:
Zur Abnahme von Werkzeugmaschinen gemäß ISO-Empfehlung R230 oder zur Überprüfung der Werkzeugspindel.

Application:
For the inspection of machine tools according to ISO recommendation R230 or for testing the tool spindle.

Application:
Pour l'inspection de machine-outils suite à la recommandation ISO R230 ou pour la vérification de la broche.

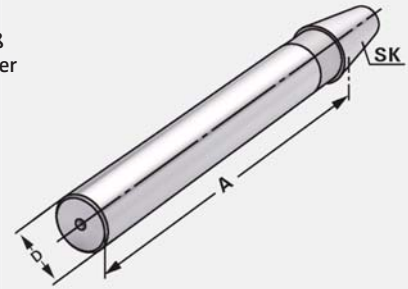

DIN 69871 Form A $\nabla \leq 0,003$ CAD

Bestell-Nr. Order no. Référence	SK	A	D	Toleranz Tolerance Tolérance	max. Rundlaufabweichung max. concentricity deviation Faux-rond max.
302.18.32	SK 30	300	32	0,003	0,003
402.18.40	SK 40	300	40	0,003	0,003
502.18.50	SK 50	300	50	0,003	0,003

Lieferumfang: Auslieferung mit Prüfprotokoll
Delivery: Delivery with test certificate
Livraison: Livraison avec rapport d'essais

Holzkasten für Kontrolldorne

Wooden box for test arbors
Coffret en bois pour mandrins de contrôle



Verwendung:
Zur Aufbewahrung von Kontrolldornen.

Application:
For the storage of test arbors.

Application:
Pour la conservation de mandrins de contrôle.



Bestell-Nr. Order no. Référence	Abmessung Size Dimension	für Kegelgrößen for cones pour cônes
701.18	460 × 130 × 115	SK 30 / 40 / 50



Hydro-Dehnspannfutter

Hydraulic expansion chucks

Mandrins expansibles hydrauliques

DIN 69871



Verwendung:

Zur Aufnahme von Werkzeugen mit Zylinderschaft nach DIN 1835 Form A+B+E und DIN 6535 Form HA+HB+HE (größer Ø 20 mm nur mit Reduzierung).

Application:

For mounting straight-shank tools acc. DIN 1835 form A+B+E and DIN 6535 form HA+HB+HE (larger than dia. 20 mm only with reduction sleeve).

Application:

Pour le serrage d'outils avec queue cylindrique suivant DIN 1835 forme A+B+E et DIN 6535 forme HA+HB+HE (à partir de dia. 20 mm seulement avec réduction).

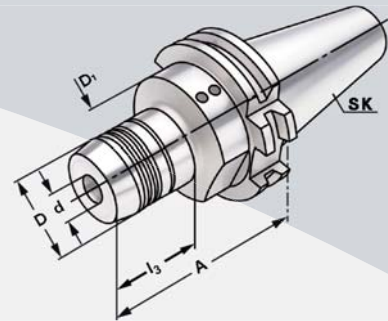

DIN 69871



$\nabla \leq 0,003$

G6,3
15.000 min⁻¹



Bestell-Nr. Order no. Référence	SK	d	A	D	D ₁	l ₁	l ₂	l ₃
302.H06*	SK 30	6	60	26	45	37	10	25
302.H08*	SK 30	8	64	28	45	37	10	29
302.H10*	SK 30	10	64	30	45	42	10	35
302.H12*	SK 30	12	72	32	45	47	10	43
302.H14*	SK 30	14	72	34	45	47	10	42
302.H16*	SK 30	16	72	38	45	52	10	43
302.H18*	SK 30	18	72	40	45	52	10	43
302.H20*	SK 30	20	90	42	42	52	10	71
403.H06	SK 40	6	68	26	50	37	10	33
403.H08	SK 40	8	68	28	50	37	10	33
403.H10	SK 40	10	72	30	50	42	10	37
403.H12	SK 40	12	77	32	50	47	10	42
403.H14	SK 40	14	77	34	50	47	10	42
403.H16	SK 40	16	80	38	50	52	10	43
403.H18	SK 40	18	80	40	50	52	10	43
403.H20	SK 40	20	82	42	50	52	10	47
403.H25	SK 40	25	117	50	63	58	10	51
403.H32	SK 40	32	117	60	63	62	10	56
403.H06.1	SK 40	6	110	26	50	37	10	33
403.H08.1	SK 40	8	110	28	50	37	10	33
403.H10.1	SK 40	10	110	30	50	42	10	37
403.H12.1	SK 40	12	110	32	50	47	10	42
403.H14.1	SK 40	14	110	34	50	47	10	42
403.H16.1	SK 40	16	110	38	50	52	10	42
403.H18.1	SK 40	18	110	40	50	52	10	47
403.H20.1	SK 40	20	110	42	50	52	10	47

* DIN 69871 Form AD
* DIN 69871 form AD
* DIN 69871 forme AD

Lieferumfang: Mit Spannschlüssel
Delivery: With wrench
Livraison: Avec clé de serrage

l₁ = max. Einstecktiefe
l₁ = max. clamping depth
l₁ = max. profondeur d'insertion

l₂ = max. Verstellweg
l₂ = max. length adjustment range
l₂ = max. course de réglage





Verwendung:

Zur Aufnahme von Werkzeugen mit Zylinderschaft nach DIN 1835 Form A+B+E und DIN 6535 Form HA+HB+HE (größer Ø 20 mm nur mit Reduzierung).

Application:

For mounting straight-shank tools acc. DIN 1835 form A+B+E and DIN 6535 form HA+HB+HE (larger than dia. 20 mm only with reduction sleeve).

Application:

Pour le serrage d'outils avec queue cylindrique suivant DIN 1835 forme A+B+E et DIN 6535 forme HA+HB+HE (à partir de dia. 20 mm seulement avec réduction).

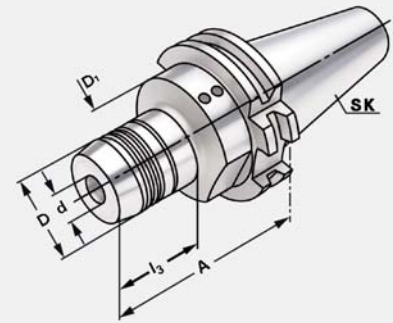

DIN 69871 Form AD/B $\leq 0,003$ G6,3 15.000 min⁻¹



Bestell-Nr. Order no. Référence	SK	d	A	D	D ₁	l ₁	l ₂	l ₃
503.H06	SK 50	6	68	26	80	37	10	33
503.H08	SK 50	8	68	28	80	37	10	33
503.H10	SK 50	10	72	30	80	42	10	37
503.H12	SK 50	12	77	32	80	47	10	42
503.H14	SK 50	14	77	34	80	47	10	42
503.H16	SK 50	16	80	38	80	52	10	45
503.H18	SK 50	18	80	40	80	52	10	45
503.H20	SK 50	20	82	42	80	52	10	47
503.H25	SK 50	25	87	50	80	58	10	52
503.H32	SK 50	32	91	60	80	62	10	56
503.H06.1	SK 50	6	110	26	50	91	10	33
503.H08.1	SK 50	8	110	28	50	91	10	33
503.H10.1	SK 50	10	110	30	50	91	10	37
503.H12.1	SK 50	12	110	32	50	91	10	42
503.H14.1	SK 50	14	110	34	50	91	10	42
503.H16.1	SK 50	16	110	38	50	91	10	42
503.H18.1	SK 50	18	110	40	50	91	10	47
503.H20.1	SK 50	20	110	42	50	91	10	47
503.H25.1	SK 50	25	110	50	80	91	10	47
503.H32.1	SK 50	32	110	60	80	91	10	75
503.H06.2	SK 50	6	150	26	50	37	10	115
503.H08.2	SK 50	8	150	28	50	37	10	115
503.H10.2	SK 50	10	150	30	50	42	10	115
503.H12.2	SK 50	12	150	32	50	42	10	115
503.H14.2	SK 50	14	150	34	50	47	10	115
503.H16.2	SK 50	16	150	38	50	52	10	115
503.H18.2	SK 50	18	150	40	50	52	10	115
503.H20.2	SK 50	20	150	42	50	52	10	115
503.H25.2	SK 50	25	150	50	50	52	10	131
503.H32.2	SK 50	32	150	60	60	62	10	131
503.H40.2	SK 50	40	150	70	70	72	10	131

Lieferumfang: Mit Spanschlüssel
Delivery: With wrench
Livraison: Avec clé de serrage

l₁ = max. Einstecktiefe l₂ = max. Verstellweg
 l₁ = max. clamping depth l₂ = max. length adjustment range
 l₁ = max. profondeur d'insertion l₂ = max. course de réglage



Schrumpffutter zum Spannen von HM und HSS Werkzeugschäften

DIN 69871



Shrink chucks for mounting of solid carbide and HSS-tool shanks

Mandrins de frettage pour le serrage de queues d'outils carbures de type HM et HSS



Verwendung:
Zur Aufnahme von Werkzeugen mit
Zylinderschaft.

Application:
For mounting straight-shank tools.

Application:
Pour le serrage d'outils avec queue
cylindrique.

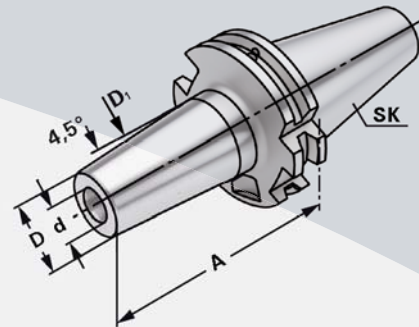

DIN 69871



$\nabla \leq 0,003$

G6,3
15.000 min⁻¹

CAD

Bestell-Nr. Order no. Référence	SK	d	A	D	D ₁	l ₁	l ₂
302.70.03	SK 30	3	80	11	15	10	–
302.70.04	SK 30	4	80	14	22	20	5
302.70.05	SK 30	5	80	16	22	20	5
302.70.06	SK 30	6	80	21	27	36	10
302.70.08	SK 30	8	80	21	27	36	10
302.70.10	SK 30	10	80	24	32	41	10
302.70.12	SK 30	12	100	24	32	47	10
302.70.14	SK 30	14	100	27	34	47	10
302.70.16	SK 30	16	100	27	34	50	10
302.70.18	SK 30	18	100	33	42	50	10
302.70.20	SK 30	20	100	33	42	52	10
302.70.03.1	SK 30	3	160	11	15	10	–
302.70.04.1	SK 30	4	160	14	22	20	5
302.70.05.1	SK 30	5	160	16	22	20	5
302.70.06.1	SK 30	6	160	21	27	36	10
302.70.08.1	SK 30	8	160	21	27	36	10
302.70.10.1	SK 30	10	160	24	32	41	10
302.70.12.1	SK 30	12	160	24	32	47	10
302.70.14.1	SK 30	14	160	27	34	47	10
302.70.16.1	SK 30	16	160	27	34	50	10
302.70.18.1	SK 30	18	160	33	42	50	10
302.70.20.1	SK 30	20	160	33	42	52	10

Für Ø 3, 4 und 5 mm nur Hartmetallschäfte verwenden!

For Ø 3, 4 and 5 mm only solid carbide tool shanks must be used!

Pour Ø 3, 4 et 5 mm il faut seulement utiliser de queues d'outils carbures de type HM!

Hinweis: Aufnahmen für Induktiv-, Kontakt- und Heißluftschumpfgeräte geeignet.
Schafttoleranz bei Ø 3, 4 und 5 mm = h₄, bei Ø 6 – Ø 32 mm = h₆

Note: Toolholders suitable for induction-, contact- and hot air shrink units.
Ø 3, 4, 5 with h₄-tolerance and Ø 6 – Ø 32 with h₆-tolerance

Observation: Porte-outils convenables pour machines à fretter par induction-,
par contact-, ou par air chaud.
Ø 3, 4, 5 avec h₄-tolerance et Ø 6 – Ø 32 avec h₆-tolerance

l₁ = max. Einstecktiefe
l₁ = max. clamping depth
l₁ = max. profondeur d'insertion

l₂ = max. Verstellweg
l₂ = max. length adjustment range
l₂ = max. course de réglage





Verwendung:
Zur Aufnahme von Werkzeugen mit Zylinderschaft.

Application:
For mounting straight-shank tools.

Application:
Pour le serrage d'outils avec queue cylindrique.

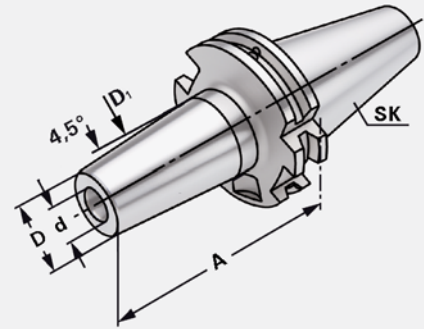

DIN 69871

Form AD/B

$\sqrt{\text{Ra}} \leq 0,003$

G6,3
15.000 min⁻¹

Bestell-Nr. Order no. Référence	SK	d	A	D	D ₁	l ₁	l ₂
403.70.03	SK 40	3	80	11	15	10	–
403.70.04	SK 40	4	80	14	22	20	5
403.70.05	SK 40	5	80	16	22	20	5
403.70.06	SK 40	6	80	21	27	36	10
403.70.08	SK 40	8	80	21	27	36	10
403.70.10	SK 40	10	80	24	32	41	10
403.70.12	SK 40	12	80	24	32	47	10
403.70.14	SK 40	14	80	27	34	47	10
403.70.16	SK 40	16	80	27	34	50	10
403.70.18	SK 40	18	80	33	42	50	10
403.70.20	SK 40	20	80	33	42	52	10
403.70.25	SK 40	25	100	44	53	58	10
403.70.32	SK 40	32	100	44	53	62	10
403.70.03.1	SK 40	3	120	11	15	10	–
403.70.04.1	SK 40	4	120	14	22	20	5
403.70.05.1	SK 40	5	120	16	22	20	5
403.70.06.1	SK 40	6	120	21	27	36	10
403.70.08.1	SK 40	8	120	21	27	36	10
403.70.10.1	SK 40	10	120	24	32	41	10
403.70.12.1	SK 40	12	120	24	32	47	10
403.70.14.1	SK 40	14	120	27	34	47	10
403.70.16.1	SK 40	16	120	27	34	50	10
403.70.18.1	SK 40	18	120	33	42	50	10
403.70.20.1	SK 40	20	120	33	42	52	10
403.70.25.1	SK 40	25	120	44	53	58	10
403.70.32.1	SK 40	32	120	44	53	62	10

Für Ø 3, 4 und 5 mm nur Hartmetallschäfte verwenden!
For Ø 3, 4 and 5 mm only solid carbide tool shanks must be used!
 Pour Ø 3, 4 et 5 mm il faut seulement utiliser de queues d'outils carbures de type HM!

Hinweis: Aufnahmen für Induktiv-, Kontakt- und Heißluftschumpfgeräte geeignet.
 Schafttoleranz bei Ø 3, 4 und 5 mm = h₄, bei Ø 6 – Ø 32 mm = h₆

Note: Toolholders suitable for induction-, contact- and hot air shrink units.
 Ø 3, 4, 5 with h₄-tolerance and Ø 6 – Ø 32 with h₆-tolerance

Observation: Porte-outils convenables pour machines à frotter par induction-,
 par contact-, ou par air chaud.
 Ø 3, 4, 5 avec h₄-tolerance et Ø 6 – Ø 32 avec h₆-tolerance

l₁ = max. Einstecktiefe l₂ = max. Verstellweg
 l₁ = max. clamping depth l₂ = max. length adjustment range
 l₁ = max. profondeur d'insertion l₂ = max. course de réglage



Schrumpffutter zum Spannen von HM und HSS Werkzeugschäften

DIN 69871



Shrink chucks for mounting of solid carbide and HSS-tool shanks

Mandrins de frettage pour le serrage de queues d'outils carbures de type HM et HSS



Verwendung:
Zur Aufnahme von Werkzeugen mit
Zylinderschaft.

Application:
For mounting straight-shank tools.

Application:
Pour le serrage d'outils avec queue
cylindrique.

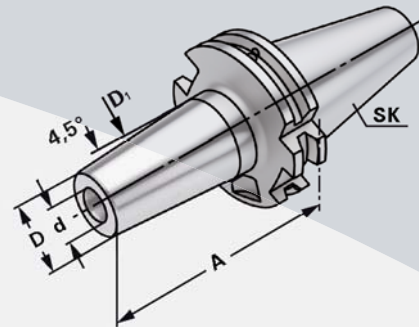

DIN 69871



$\nabla \leq 0,003$

G6,3
15.000 min⁻¹

Bestell-Nr. Order no. Référence	SK	d	A	D	D ₁	l ₁	l ₂
403.70.03.2	SK 40	3	160	11	15	10	10
403.70.04.2	SK 40	4	160	14	22	20	10
403.70.05.2	SK 40	5	160	16	22	20	10
403.70.06.2	SK 40	6	160	21	27	36	10
403.70.08.2	SK 40	8	160	21	27	36	10
403.70.10.2	SK 40	10	160	24	32	41	10
403.70.12.2	SK 40	12	160	24	32	47	10
403.70.14.2	SK 40	14	160	27	34	47	10
403.70.16.2	SK 40	16	160	27	34	50	10
403.70.18.2	SK 40	18	160	33	42	50	10
403.70.20.2	SK 40	20	160	33	42	52	10
403.70.25.2	SK 40	25	160	44	53	58	10
403.70.32.2	SK 40	32	160	44	53	62	10
503.70.03	SK 50	3	80	11	15	10	10
503.70.04	SK 50	4	80	14	22	20	10
503.70.05	SK 50	5	80	16	22	20	10
503.70.06	SK 50	6	80	21	27	36	10
503.70.08	SK 50	8	80	21	27	36	10
503.70.10	SK 50	10	80	24	32	41	10
503.70.12	SK 50	12	80	24	32	47	10
503.70.14	SK 50	14	80	27	34	47	10
503.70.16	SK 50	16	80	27	34	50	10
503.70.18	SK 50	18	80	33	42	50	10
503.70.20	SK 50	20	80	33	42	52	10
503.70.25	SK 50	25	100	44	53	58	10
503.70.32	SK 50	32	100	44	53	62	10

Für Ø 3, 4 und 5 mm nur Hartmetallschäfte verwenden!

For Ø 3, 4 and 5 mm only solid carbide tool shanks must be used!

Pour Ø 3, 4 et 5 mm il faut seulement utiliser de queues d'outils carbures de type HM!

Hinweis: Aufnahmen für Induktiv-, Kontakt- und Heißluftschumpfgeräte geeignet.
Schafttoleranz bei Ø 3, 4 und 5 mm = h₄, bei Ø 6 – Ø 32 mm = h₆

Note: Toolholders suitable for induction-, contact- and hot air shrink units.
Ø 3, 4, 5 with h₄-tolerance and Ø 6 – Ø 32 with h₆-tolerance

Observation: Porte-outils convenables pour machines à fretter par induction-,
par contact-, ou par air chaud.
Ø 3, 4, 5 avec h₄-tolerance et Ø 6 – Ø 32 avec h₆-tolerance

l₁ = max. Einstecktiefe
l₁ = max. clamping depth
l₁ = max. profondeur d'insertion

l₂ = max. Verstellweg
l₂ = max. length adjustment range
l₂ = max. course de réglage



Shrink chucks for mounting of solid carbide and HSS-tool shanks
Mandrins de frettage pour le serrage de queues d'outils carbures
de type HM et HSS



Verwendung:
Zur Aufnahme von Werkzeugen mit
Zylinderschaft.

Application:
For mounting straight-shank tools.

Application:
Pour le serrage d'outils avec queue
cylindrique.

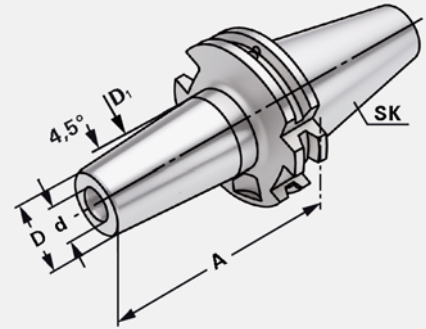

DIN 69871

Form
AD/B

$\sqrt{\text{Ra}} \leq 0,003$

G6,3
15.000 min⁻¹

Bestell-Nr. Order no. Référence	SK	d	A	D	D ₁	l ₁	l ₂
503.70.06.1	SK 50	6	160	21	27	36	10
503.70.08.1	SK 50	8	160	21	27	36	10
503.70.10.1	SK 50	10	160	24	32	41	10
503.70.12.1	SK 50	12	160	24	32	47	10
503.70.14.1	SK 50	14	160	27	34	47	10
503.70.16.1	SK 50	16	160	27	34	50	10
503.70.18.1	SK 50	18	160	33	42	50	10
503.70.20.1	SK 50	20	160	33	42	52	10
503.70.25.1	SK 50	25	160	44	53	58	10
503.70.32.1	SK 50	32	160	44	53	62	10
503.70.06.2	SK 50	6	200	21	27	36	10
503.70.08.2	SK 50	8	200	21	27	36	10
503.70.10.2	SK 50	10	200	24	32	41	10
503.70.12.2	SK 50	12	200	24	32	47	10
503.70.14.2	SK 50	14	200	27	34	47	10
503.70.16.2	SK 50	16	200	27	34	50	10
503.70.18.2	SK 50	18	200	33	42	50	10
503.70.20.2	SK 50	20	200	33	42	52	10
503.70.25.2	SK 50	25	200	44	53	58	10
503.70.32.2	SK 50	32	200	44	53	62	10

Hinweis: Aufnahmen für Induktiv-, Kontakt- und Heißluftschumpfgeräte geeignet.
Schafttoleranz bei $\varnothing 6 - \varnothing 32$ mm = h₆

Note: Toolholders suitable for induction-, contact- and hot air shrink units.
 $\varnothing 6 - \varnothing 32$ with h₆-tolerance

Observation: Porte-outils convenables pour machines à fretter par induction-,
par contact-, ou par air chaud.
 $\varnothing 6 - \varnothing 32$ avec h₆-tolerance

l₁ = max. Einstecktiefe l₂ = max. Verstellweg
l₁ = max. clamping depth l₂ = max. length adjustment range
l₁ = max. profondeur d'insertion l₂ = max. course de réglage



Schrumpffutter mit Kühlkanälen zum Spannen von HM und HSS Werkzeugschäften

DIN 69871



Shrink chucks with cooling channels for mounting of solid carbide and HSS-tool shanks

Mandrins de frettage avec canaux d'arrosage pour le serrage de queues d'outils carbures de type HM et HSS



Verwendung:
Zur Aufnahme von Werkzeugen mit Zylinderschaft.

Application:
For mounting straight-shank tools.

Application:
Pour le serrage d'outils avec queue cylindrique.

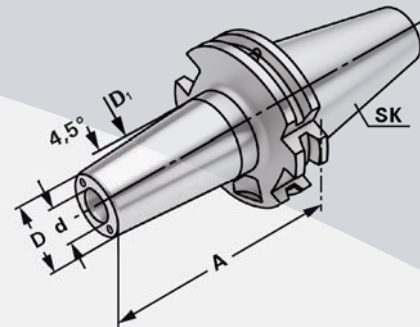

DIN 69871



$\nabla \leq 0,003$

G6,3
15.000 min⁻¹

Bestell-Nr. Order no. Référence	SK	d	A	D	D ₁	l ₁	l ₂
403.70.06.K	SK 40	6	80	21	27	36	10
403.70.08.K	SK 40	8	80	21	27	36	10
403.70.10.K	SK 40	10	80	24	32	41	10
403.70.12.K	SK 40	12	80	24	32	47	10
403.70.14.K	SK 40	14	80	27	34	47	10
403.70.16.K	SK 40	16	80	27	34	50	10
403.70.18.K	SK 40	18	80	33	42	50	10
403.70.20.K	SK 40	20	80	33	42	52	10
403.70.25.K	SK 40	25	100	44	53	58	10
403.70.32.K	SK 40	32	100	44	53	62	10
503.70.06.K	SK 50	6	80	21	27	36	10
503.70.08.K	SK 50	8	80	21	27	36	10
503.70.10.K	SK 50	10	80	24	32	41	10
503.70.12.K	SK 50	12	80	24	32	47	10
503.70.14.K	SK 50	14	80	27	34	47	10
503.70.16.K	SK 50	16	80	27	34	50	10
503.70.18.K	SK 50	18	80	33	42	50	10
503.70.20.K	SK 50	20	80	33	42	52	10
503.70.25.K	SK 50	25	100	44	53	58	10
503.70.32.K	SK 50	32	100	44	53	62	10

Für Ø 3, 4 und 5 mm nur Hartmetallschäfte verwenden!

For Ø 3, 4 and 5 mm only solid carbide tool shanks must be used!

Pour Ø 3, 4 et 5 mm il faut seulement utiliser de queues d'outils carbures de type HM!

Hinweis: Aufnahmen für Induktiv-, Kontakt- und Heißluftschumpfergeräte geeignet.
Schafttoleranz bei Ø 6 – Ø 32 mm = h₆

Note: Toolholders suitable for induction-, contact- and hot air shrink units.
Ø 6 – Ø 32 with h₆-tolerance

Observation: Porte-outils convenables pour machines à fretter par induction-, par contact-, ou par air chaud.
Ø 6 – Ø 32 avec h₆-tolerance

l₁ = max. Einstecktiefe

l₁ = max. clamping depth

l₁ = max. profondeur d'insertion

l₂ = max. Verstellweg

l₂ = max. length adjustment range

l₂ = max. course de réglage



KEMMLER

1.44



Verwendung:

Zur Aufnahme von Einschraubfräser mit Gewinde.

Application:

For mounting screw-in cutters with thread.

Application:

Pour le serrage de fraises à queue fileté.

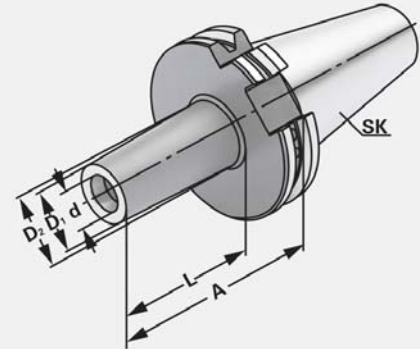

DIN 69871 Form AD/B $\sqrt{\leq 0,003}$ G6,3 15.000 min⁻¹

Bestell-Nr. Order no. Référence	SK	M	d ^{H4}	D ₁	D ₂	A	L
403.06.06	SK 40	6	6,5	10	13	44	25
403.06.06.1	SK 40	6	6,5	10	13	69	50
403.06.06.2	SK 40	6	6,5	10	13	94	75
403.06.08	SK 40	8	8,5	13	15	44	25
403.06.08.1	SK 40	8	8,5	13	23	69	50
403.06.08.2	SK 40	8	8,5	13	23	94	75
403.06.08.3	SK 40	8	8,5	13	25	119	100
403.06.10.0	SK 40	10	11	18	18	24	5
403.06.10.1	SK 40	10	11	18	23	69	50
403.06.10.3	SK 40	10	11	18	32	119	100
403.06.10.5	SK 40	10	11	18	37	169	150
403.06.12.0	SK 40	12	13	21	21	24	5
403.06.12.1	SK 40	12	11	21	24	69	50
403.06.12.3	SK 40	12	11	21	33	119	100
403.06.12.5	SK 40	12	11	21	40	169	150
403.06.16.0	SK 40	16	17	29	29	24	5
403.06.16.1	SK 40	16	17	29	34	69	50
403.06.16.3	SK 40	16	17	29	36	119	100
403.06.16.5	SK 40	16	17	29	43	169	105
503.06.08.1	SK 50	8	8,5	13	23	69	50
503.06.08.3	SK 50	8	8,5	13	25	119	100
503.06.08.5	SK 50	8	8,5	13	30	169	150
503.06.10.1	SK 50	10	11	18	23	69	50
503.06.10.3	SK 50	10	11	18	32	119	100
503.06.10.5	SK 50	10	11	18	37	169	150
503.06.12.1	SK 50	12	13	21	24	69	50
503.06.12.3	SK 50	12	13	21	33	119	100
503.06.12.5	SK 50	12	13	21	40	169	150
503.06.16.1	SK 50	16	16	29	34	69	50
503.06.16.3	SK 50	16	16	29	36	119	100
503.06.16.5	SK 50	16	16	29	43	169	150



Steilkegelaufnahmen mit Plananlage

Steep taper toolholders with full face contact

Porte-outils conique avec cône face

DIN 69871



Mit dem Einsatz von Steilkegelaufnahmen mit Plananlage können auf herkömmlichen CNC-Maschinen mit der Standardspindel die Maschinenleistungen durch eine wesentlich höhere Stabilität voll genutzt werden.

Die exakte Abstimmung zwischen Maschinenspindel und Steilkegelaufnahme mit Plananlage erfolgt über einen patentierten Abstimmungsring.

Die Lage der Greiferrille für den Werkzeugwechsler wird dadurch nicht verändert.

Die Vorteile sind:

- Maschinenleistung kann voll genutzt werden
- Steilkegelaufnahmen mit Planscheibe werden auf die vorhandene Maschinenspindel abgestimmt
- Stabile und vergrößerte, vollständige Plananlage
- Standard Steilkegelaufnahmen können weiterhin genutzt werden
- Weniger Vibrationen aufgrund der großen Plananlage
- Verbesserte Oberflächengüte und prozesssichere Maßhaltigkeit am Werkstück
- Höhere Standzeit der Schneidwerkzeuge
- Bessere Werkzeugwechsel-Wiederholgenauigkeit
- Kein Stabilitätsverlust bei hohen Spindeldrehzahlen

By using steep taper toolholders with full face contact on conventional CNC-machines with standard spindles, the performance of the machine can be utilised completely due to a highly improved stability.

The exact alignment between machine spindle and steep taper toolholder with full face contact is realized by a patented dual face contact plate.

The position of the gripper groove for the tool changer remains unchanged.

The advantages are:

- Machine performance can be utilised to the full extent
- Steep taper toolholders will be aligned with existing machine spindles
- Stable and bigger, complete full face contact
- Users can continue to use standard steep taper toolholders
- Less vibrations due to large full face contact
- Better surface finish and higher reliability of processing
- Longer service life of the cutting tools
- Better tool change repeat accuracy
- No loss of stability at high spindle speeds



Par l'utilisation de porte-outils conique avec cône face sur machine-outils avec broche standard on peut profiter d'une puissance de machine-outil élevé à cause d'une stabilité plus forte.

L'harmonisation exacte entre la broche et le porte-outil avec cône face est réalisé par une bague de contact.

La position de la rainure pour le changeur automatique d'outils ne change pas.

Les avantages sont:

- La rendement de machine peut être utilisée entièrement
- Porte-outils conique avec cône face sont harmonisé avec la broche standard
- Cône face entière, stable et élargi
- Porte-outils conique standard peuvent être utilisés toujours
- Moins vibrations à cause de cône face élargi
- Finition de surface et sécurité du processus de la pièce usinée améliorés
- Tenue de coupe prolongée
- Exactitude de changement d'outil amélioré
- Pas de perte de stabilité à grande vitesse de la broche

