



CATALOGO
CATALOGUE
2013

STOARM®



STRUMENTI DI MISURA E CONTROLLO

MEASURING AND CONTROL INSTRUMENTS



CENTRO DI TARATURA ACCREDIA



LAT N° 067

Membro degli Accordi di Mutuo Riconoscimento EA, IAF, e ILAC

Le attività riportate nel presente documento non sono coperte dall'accREDITAMENTO se non espressamente indicato.

Le Officine meccaniche LTF SpA operano da anni nel settore della fabbricazione, verifica e messa a punto di strumentazione, apparecchiature e macchine per le lavorazioni meccaniche di precisione. Ha il suo insediamento principale su un'area di 55.000 m² con più di 20.000 m² coperti. Dopo aver iniziato l'attività nel 1965 con la produzione e commercializzazione di utensileria e apparecchiature magnetiche speciali, l'azienda ha incrementato di pari passo la propria azione commerciale e tecnico-produttiva, ottenendo la certificazione ISO 9001/2008, ed inserendosi con ruolo sempre più importante, in attività di alto contenuto tecnologico, nel campo della Metrologia di misura e di controllo, senza abbandonare i propri settori produttivi più tradizionali. Assume così progressivamente nel tempo, le attività:

- **BORLETTI - Strumenti di misura e controllo**
- **MICROTECNICA - Proiettori di profili**
- **GALILEO - Durometria**

ed assieme a quella relativa al Centro di Taratura ACCREDIA LAT n° 067, realizzato nel 1993 e costituito da 2 sale Metrologiche accreditate per Tarature ACCREDIA, le raggruppa nella Divisione METROLOGIA, con tecnici di esperienza nel settore, che supportano costantemente una qualificata ed ampia rete di vendita nazionale ed internazionale protesa ad offrire alla clientela un servizio completo ed aggiornato. Rappresenta in esclusiva per l'Italia importanti case tedesche di utensili ed elettro utensili, collabora con qualificati partners internazionali nello sviluppo e ricerca di nuovi prodotti e tecnologie.

DIVISIONI AZIENDALI:

	APPARECCHIATURE MAGNETICHE ATTREZZATURE ANTINFORTUNISTICHE STRUMENTI MECCANICI MACCHINE UTENSILI	
BORLETTI	STRUMENTI DI MISURA E CONTROLLO DI PRECISIONE	
GALILEO durometria	MISURATORI DI DUREZZA E DI MICRODUREZZA	
MICROTECNICA Proiettori di profili	PROIETTORI DI PROFILI SISTEMI OTTICI DI MISURA	
ASTURO	AEROGRAFI E SISTEMI DI VERNICIATURA - UTENSILI PNEUMATICI - RACCORDERIA	
IM	INDUSTRIE MECCANICHE TRAPANI SENSITIVI E MASCHIATRICI DI ALTA PRECISIONE	
7 la prora	AFFILATRICI UNIVERSALI E RETTIFICATRICI IDRAULICHE	
BREDA	TRAPANI RADIALI	
Tommasi & Bonetti ELECTROMECHANICA	ELETTROMECCANICA	
CUTER	MORSE DI PRECISIONE Made in Italy	
STORM	STRUMENTI DI MISURA E CONTROLLO	
TAVOLAZZI UTENSILERIA ITALIANA	UTENSILERIA ITALIANA UTENSILI DA TAGLIO	
WEMEX Germany	UTENSILI DA TAGLIO STRUMENTI ATTREZZATURE ELETTROUTENSILI	
RAPPRESENTANZE ESCLUSIVE PER L'ITALIA		
WERKO Germany	PUNTE ELICOIDALI UTENSILI DA TAGLIO	
KOCH-BOHRER Germany	PUNTE DA MURO E LEGNO	
IORI JEB	STRUMENTI DI MISURA ATTREZZATURE PER FERRAMENTA ED EDILIZIA	
ABRATOOLS sa	ABRASIVI	
OPTIMUM MASCHINEN - GERMANY	MACCHINE UTENSILI ED ATTREZZATURE	
PRT TOOLS	MANDRINERIA PER MACCHINE CNC PER LA LAVORAZIONE DEI METALLI E DEL LEGNO	
MANN HOLZ MASCHINEN AUSTRIA	MACCHINE PER LA LAVORAZIONE DEL LEGNO	
IMPORTATORE PER L'ITALIA DI:		
Xcalibur woodworking	MACCHINE ED ATTREZZATURE PER IL LEGNO	
unicraft Werkstatttechnik	SISTEMI DI SOLLEVAMENTO	
C CLEVELAND	PUNTE ELICOIDALI ED UTENSILI DA TAGLIO Made in England	
FELISATTI	ELETTROUTENSILI	

CALIBRI CALIPERS

Il calibro a corsoio STORM è frutto di pluriennale esperienza tecnologica realizzato secondo la normativa DIN 862.

STORM high precision vernier calipers are realized according to DIN 862 standards.

Lunghezza misurata in mm Measuring length mm	Errore minimo di misura ammesso in $\pm \mu$ Permissible deviation of the reading in $\pm \mu$
0 - 200	40
200 - 300	50
300 - 400	70
400 - 500	80
500 - 600	90
600 - 700	100
700 - 800	110
800 - 900	120
900 - 1000	130
1000 - 1100	140
1100 - 1200	160
1200 - 1300	170
1300 - 1400	180
1400 - 1500	190
1500 - 1600	200
1600 - 1700	210
1700 - 1800	220
1800 - 1900	230
1900 - 2000	240
oltre 2000	250

CALIBRO CINQUANTESIMALE PER INGRANAGGI GEAR TOOTH VERNIER CALIPER, GRADUATION 0.02 mm

Calibro in acciaio INOX, bloccaggio doppio nonio superiore a vite.

Vernier caliper made of stainless steel, upper vernier double screw locks.

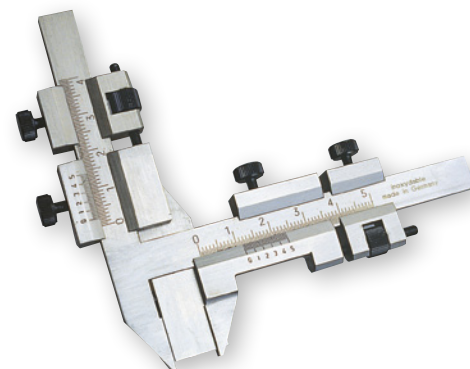

ART. CO61

COD.	Modulo Module	Lettura doppio nonio Double vernier reading mm
2341	1 ÷ 26	0,02

Precisione secondo: Norme DIN862 / Accuracy according to DIN 862



CALIBRO PER FRENI CALIPER FOR BRAKE DISKS

Calibro in acciaio
INOX.

*Vernier calipers
made of stainless
steel.*

ART. CPF

COD.	Campo di misura Range mm	Becchi Jaws mm
950	0 ÷ 60	85

Precisione secondo: Norme DIN862 / Accuracy according to DIN 862



CALIBRI CINQUANTESIMALI CALIPERS, GRADUATION 0.02 mm

Calibri a corsoio
in acciaio INOX
satinato di alta
precisione con vite
micrometrica.

*High precision
vernier calipers
made of stainless
steel, satin-chrome
finish, with fine
adjustment.*

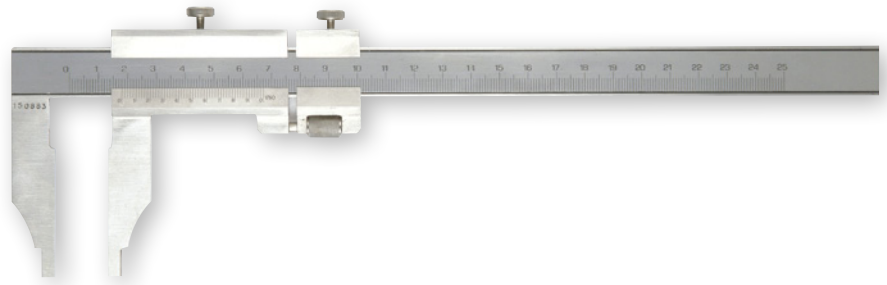

ART. AZC/10

COD.	Campo di misura Range mm	Lunghezza scala Scale length mm	Becchi Jaws mm
650	200	250	65
651	250	300	80
652	250	300	125
653	300	350	90
654	300	350	150
655	400	450	90
992	400	450	125
656	400	450	150
657	400	450	200
658	500	550	125
659	500	550	150
660	500	550	200
661	500	550	250
662	600	650	125
663	600	650	150
664	600	650	200
665	600	650	250
666	600	650	300
667	800	850	150
668	800	850	200

COD.	Campo di misura Range mm	Lunghezza scala Scale length mm	Becchi Jaws mm
669	800	850	300
697	800	850	400
670	1000	1050	150
671	1000	1050	200
672	1000	1050	300
673	1000	1050	500
674	1200	1250	150
994	1200	1250	200
999	1200	1250	300
675	1500	1550	150
996	1500	1550	200
676	1500	1550	300
677	1500	1550	500
678	2000	2050	300
679	2000	2050	500
997	2500	2550	200
680	2500	2550	300
998	3000	3050	200
681	3000	3050	300
688	4000	4050	300

Precisione secondo: Norme DIN862 / Accuracy according to DIN 862

Confezione: astuccio similpelle – A richiesta cassetta legno di faggio evaporato fino alla misura 3000 mm (vedi tabella p.5 rif. cassetta legno)
Supplied in leatherette sheath – Dried beech wood case up to 3000 mm length available upon request. (see table on page 5 . Ref. "Wooden cases")

CALIBRI CINQUANTESIMALI CON BECCHI SUPERIORI PER ESTERNI CALIPERS WITH UPPER JAWS FOR EXTERNAL MEASUREMENTS, GRADUATION 0.02 mm

Calibri a corsoio
in acciaio INOX
satinato con vite
micrometrica.

*High precision
vernier calipers
made of stainless
steel, satin-chrome
finish, with fine
adjustment.*

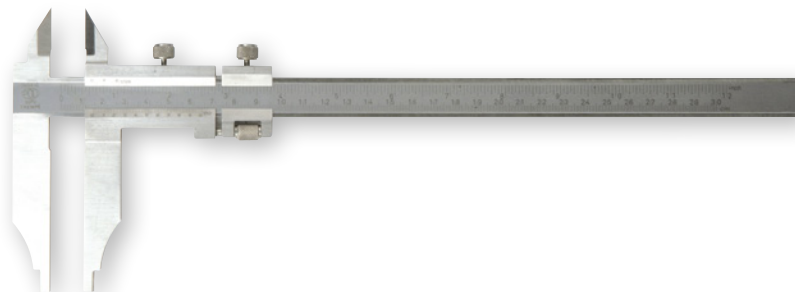

ART. AZC/41

COD.	Campo di misura Range mm	Lunghezza scala Scale length mm	Becchi Jaws mm
750	200	250	65
751	250	300	80
752	300	350	90
758	400	450	125
753	400	450	150
759	400	450	200
754	500	550	150
760	500	550	200
761	500	550	250
755	600	650	150
762	600	650	200
763	600	650	300
756	800	850	150
764	800	850	200

COD.	Campo di misura Range mm	Lunghezza scala Scale length mm	Becchi Jaws mm
765	800	850	300
757	1000	1050	150
766	1000	1050	200
767	1000	1050	300
768	1200	1250	200
769	1200	1250	300
770	1500	1550	200
771	1500	1550	300
772	2000	2050	200
773	2000	2050	300
774	2500	2550	200
775	2500	2550	300
776	3000	3050	200
777	3000	3050	300

Precisione secondo: Norme DIN862 / Accuracy according to DIN 862

Confezione: astuccio similpelle / A richiesta cassetta legno di faggio evaporato (vedi tabella p.5 rif. astucci legno)

Supplied in leatherette sheath / Dried beech wood case available upon request. (see table on page 5 . Ref. "Wooden cases")

CALIBRI CINQUANTESIMALI CON BECCHI SUPERIORI PER INTERNI CALIPERS WITH UPPER JAWS FOR INSIDE MEASUREMENTS, GRADUATION 0.02 mm

Calibri a corsoio
in acciaio INOX
satinato con vite
micrometrica.

*High precision
vernier calipers
made of stainless
steel, satin-chrome
finish, with fine
adjustment.*

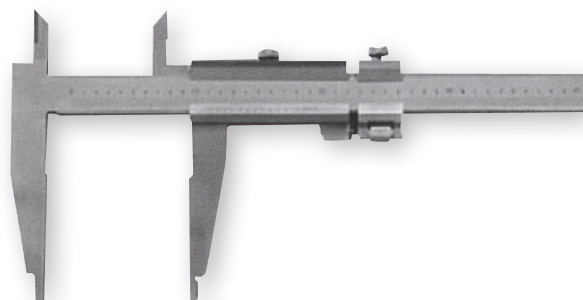

ART. AZC/42

COD.	Campo di misura Range mm	Lunghezza scala Scale length mm	Becchi Jaws mm
850	200	250	65
851	250	300	80
852	300	350	90
853	400	450	150
854	500	550	150
855	600	650	150
856	800	850	150
857	1000	1050	150

Precisione secondo: Norme DIN862 / Accuracy according to DIN 862

Confezione: astuccio similpelle / A richiesta cassetta legno di faggio evaporato (vedi tabella p.5 rif. astucci legno)

Supplied in leatherette sheath / Dried beech wood case available upon request. (see table on page 5 . Ref. "Wooden cases")

CASSETTA LEGNO – FAGGIO EVAPORATO DRIED BEECH WOOD CASE



ART.	mm	ART.	mm	ART.	mm	ART.	mm	ART.	mm	ART.	mm
70029	350x90	70031	550x115	70049	650x200	70521	850x400	70522	1250x200	70037	2050x300
70042	350x150	70045	550x150	70050	650x250	70034	1050x150	70523	1250x300	70058	2050x500
70030	450x90	70046	550x200	70051	650x300	70054	1050x200	70036	1550x150	70526	2550x200
70520	450x125	70047	550x250	70033	850x150	70055	1050x300	70524	1550x200	70035	2550x300
70043	450x150	70032	650x115	70052	850x200	70056	1050x500	70040	1550x300	70527	3050x200
70044	450x200	70048	650x150	70053	850x300	70334	1250x150	70057	1550x500	70528	3050x300

CALIBRI CINQUANTESIMALI DI PROFONDITÀ DEPTH GAUGES, GRADUATION 0.02 mm

Calibri di profondità in acciaio INOX satinato con vite micrometrica.

Depth gauges made of stainless steel, satin-chrome finish, with fine adjustment.

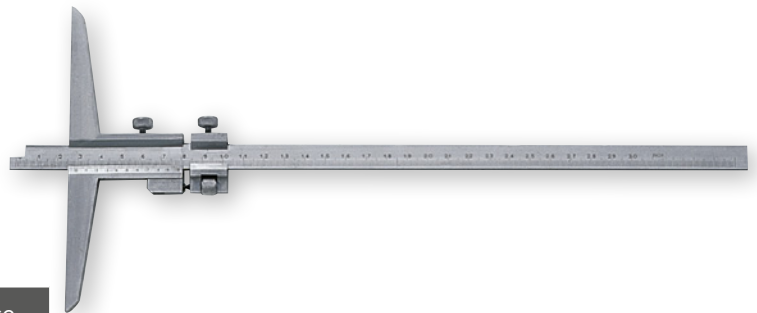

ART. C054/1

COD.	Campo di misura Range mm	Lunghezza scala Scale length mm	Base mm
2250	200	250	150
2251	250	300	150
2252	350	400	150
2253	450	500	150
2277	160	200	80
2276	250	300	80

Precisione secondo: Norme DIN862 / Accuracy according to DIN 862
Confezione: astuccio similpelle / Supplied in leatherette sheath

CALIBRI CINQUANTESIMALI DI PROFONDITÀ DEPTH GAUGES, GRADUATION 0.02 mm

Calibri di profondità in acciaio INOX satinato.

Depth gauges made of stainless steel, satin-chrome finish.



ART. C057/1

COD.	Campo di misura Range mm	Lunghezza scala Scale length mm	Base mm
2270	150	200	80
2271	200	250	80
2272	250	300	80
2273	300	350	80
2274	400	450	80

Precisione secondo: Norme DIN862 / Accuracy according to DIN 862
Confezione: astuccio similpelle / Supplied in leatherette sheath

CALIBRI VENTESIMALI DI PROFONDITÀ PER GOLE INTERNE

DEPTH GAUGES CALIPERS FOR GROOVE MEASUREMENT, GRADUATION 0.05 mm

Calibri di
profondità in
acciaio INOX
satinato con spillo.

Depth gauges
made of stainless
steel, satin-chrome
finish, with hook.



ART. C059/1

COD.	Campo di misura Range mm	Lunghezza scala Scale length mm	Base mm
2310	150	200	80
2311	200	250	80
2312	250	300	80
2313	300	350	80
2314	400	450	80

Precisione secondo: Norme DIN862 / Accuracy according to DIN 862
Confezione: astuccio similpelle / Supplied in leatherette sheath

CALIBRI VENTESIMALI DI PROFONDITÀ PER GOLE INTERNE

DEPTH GAUGES CALIPERS FOR GROOVE MEASUREMENT, GRADUATION 0.05 mm

Calibri di
profondità in
acciaio INOX
satinato.

Depth gauges
made of stainless
steel, satin-chrome
finish, with hook.

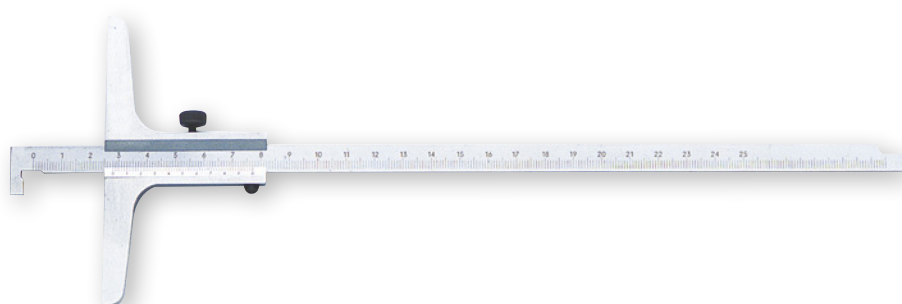

ART. C060/1

COD.	Campo di misura Range mm	Lunghezza scala Scale length mm	Base mm
2330	150	200	80
2331	200	250	80
2332	250	300	80
2333	300	350	80
2334	400	450	80

ART. C064/1

COD.	Campo di misura Range mm	Lunghezza scala Scale length mm	Base mm
13521	150	200	105
13523	200	250	105
13525	250	300	125
13527	300	350	125
13528	300	350	150
13530	400	450	150
13531	500	550	150

Precisione secondo: Norme DIN862 / Accuracy according to DIN 862
Confezione: astuccio similpelle / Supplied in leatherette sheath

CALIBRI DIGITALI LETTURA CENTESIMALE DIGITAL VERNIER CALIPERS – READING 0,01 mm (0,0005")



Calibri digitali in acciaio INOX con vite micrometrica.

Digital vernier calipers made of stainless steel with fine adjustment.

ART. AZD/40

COD.	Campo di misura Range mm	Lunghezza scala Scale length mm	Becchi Jaws mm
547	200	250	65
555	250	300	80
548	300	350	100
556	300	350	150
557	400	450	125
549	500	550	150
550	500	550	200

COD.	Campo di misura Range mm	Lunghezza scala Scale length mm	Becchi Jaws mm
551	600	650	150
552	600	650	200
553	800	850	150
554	800	850	200
563	1000	1050	150
564	1000	1050	200

Precisione secondo: Norme DIN862 / Accuracy according to DIN 862
Confezione: cassetta legno di faggio evaporato / Supplied in dried wood beech case

CALIBRI DIGITALI LETTURA CENTESIMALE DIGITAL VERNIER CALIPERS – READING 0,01 mm (0,0005")



Calibri digitali in acciaio INOX con punte e vite micrometrica.

Digital vernier calipers made of stainless steel, with inside jaws and fine adjustment.

ART. AZD/41

COD.	Campo di misura Range mm	Lunghezza scala Scale length mm	Becchi Jaws mm
709	300	350	60
711	500	550	150
712	600	650	150
713	1000	1050	150
714	1500	1550	200
715	2000	2050	200

Precisione secondo: Norme DIN862 / Accuracy according to DIN 862
Confezione: cassetta legno di faggio evaporato / Supplied in dried wood beech case



CALIBRI DIGITALI DI PROFONDITÀ LETTURA CENTESIMALE DIGITAL DEPTH GAUGES – READING 0,01 mm (0,0005")



Calibri digitali in acciaio INOX.

Digital depth gauges made of stainless steel.

ART. C054/D

COD.	Campo di misura Range mm	Base mm
2254	150	100
2255	200	100
2256	250	100
2260	300	150
2257	500	150

Precisione secondo: Norme DIN862 / Accuracy according to DIN 862
Confezione: cassetta legno di faggio evaporato / Supplied in dried wood beech case



CALIBRI VENTESIMALI PER TRACCIATURE TRAMMEL GAUGE, GRADUATION 0.05 mm

Calibri analogici
in acciaio
indeformabile
senza vite
micrometrica.

*Trammel gauges
made of carbon
steel without fine
adjustment.*

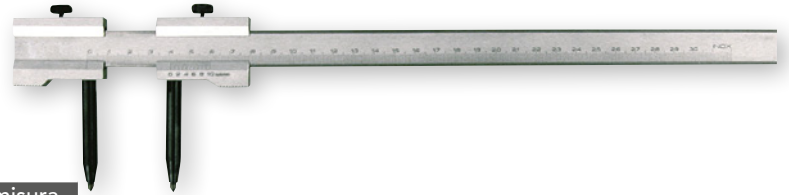

ART. C80

COD.	Campo di misura Range mm	COD.	Campo di misura Range mm
4100	300	4103	1500
4101	500	4104	2000
4102	1000	4105	3000

Confezione: astuccio similpelle / Supplied in leatherette sheath

CALIBRI VENTESIMALI PER TRACCIATURE TRAMMEL GAUGE, GRADUATION 0.05 mm

Calibri analogici
in acciaio
indeformabile con
vite micrometrica.

*Trammel gauges
made of carbon
steel with fine
adjustment.*



ART. C300

COD.	Campo di misura Range mm	COD.	Campo di misura Range mm
4110	300	4113	1500
4111	500	4114	2000
4112	1000	4115	3000

Confezione: astuccio similpelle / Supplied in leatherette sheath

ART. C310 4120

**COPPIA PUNTE DI RICAMBIO
PER C80 E C300**
SET OF TWO SPARE TRAMMEL POINTS
FOR C80 AND C300

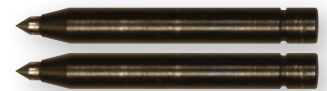

CALIBRO PER TRACCIATURA IN ACCIAIO INOX MARKING VERNIER CALIPER MADE OF STAINLESS STEEL



ART. CT

COD.	Campo di misura Range mm	Nonio Reading
2375	200	1/10 - 1/128"

Confezione: astuccio similpelle / Supplied in leatherette sheath

TRACCIATORI - TRAMMEL GAUGES

TRACCIATORI PER MECCANICI WORKSHOP TRAMMEL GAUGES FOR TRACING AND MARKING

Asta tonda in acciaio.

Round rod made of steel.

ART. C320

COD.	Campo di misura / Range mm
4125	200
4126	500

Confezione: plastica / Supplied in plastic case



TRACCIATORE / TRAMMEL GAUGES

Asta e corsoio tondi in acciaio.

Round rod and vernier made of steel.

ART. C320/N

COD.	Campo di misura / Range mm
4116	300

Confezione: plastica / Supplied in plastic case

ART. C330 4130

PUNTA DI RICAMBIO PER C320 e C320/N SPARE POINT FOR C320 and C320/N

TRUSCHINI - HEIGHT GAUGES

TRUSCHINI CINQUANTESIMALI HEIGHT GAUGES, GRADUATION 0.02 mm

Truschini in acciaio INOX temprato, asta cromata con vite micrometrica. Bloccaggio a vite.

Height gauges made of hardened stainless steel, chrome finish with fine adjustment and locking screw.

ART. T100

COD.	Campo di misura Range mm	Lunghezza scala Scale length mm
2541	300	350
2543	400	450
2545	500	550
2546	600	650
2547	800	850
2548	1000	1050

Precisione secondo: Norme DIN862 / Accuracy according to DIN 862
Confezione: scatola cartone / Supplied in cardboard box

ART. T5 2570

PUNTA DI RICAMBIO PER TRUSCHINI IN ACCIAIO STEEL SPARE POINT FOR HEIGHT GAUGES



TRUSCHINI DIGITALI / DIGITAL HEIGHT GAUGES



Truschini digitali in acciaio INOX.
Spegnimento automatico, lettura mm/inch,
vite micrometrica, punta tracciare in widia.

Digital height gauges made of stainless
steel with fine adjustment
and carbide tipped scriber.

ART. TRD

COD.	Campo di misura / Range mm
2622	400
2623	600
2624	1000

Precisione secondo: Norme DIN862 / Accuracy according to DIN 862
Confezione: cassetta legno / Supplied in wooden case



GONIOMETRI - PROTRACTORS

GONIOMETRO CON LETTURA QUADRA PROTRACTOR, READING IN SQUARE WINDOW

In acciaio INOX cromato.

Made of chrome-finished stainless steel.

ART. R08/F

COD.	Asta / Rod mm
2425	240

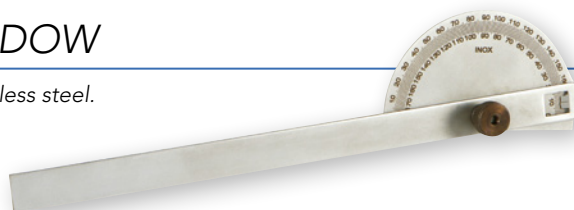

GONIOMETRO CON LETTURA DIRETTA / PROTRACTOR, DIRECT READING

In acciaio INOX cromato.

Made of chrome-finished stainless steel.

ART. R09/F

COD.	Asta / Rod mm
2426	240



GONIOMETRI SEMPLICI / PROTRACTORS

In acciaio cromato.

Made of chrome steel.

ART. G01

COD.	Arco / Arc mm	Asta - Rod mm
2430	80	120
2431	120	150
2432	150	200
2433	200	300
2434	250	500
2435	300	600



GONIOMETRI AD ASTA SCORREVOLE PROTRACTORS WITH ADJUSTABLE BLADE

In acciaio cromato.

Made of chrome steel.

ART. S180

COD.	Arco / Arc mm	Asta / Rod mm
2440	120	240
2441	150	300
2442	200	400
2443	250	500
2444	300	600

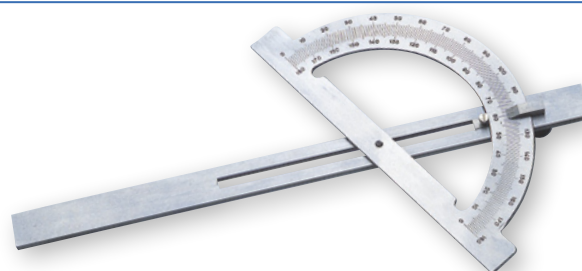

CALIBRO E MISURATORE - DEPTH AND DIAL GAUGE

CALIBRO DI PROFONDITÀ PER BATTISTRADA PNEUMATICI DEPTH GAUGE FOR PNEUMATIC TYRE TREADS

In acciaio INOX. *Made of stainless steel.*

ART. CBP

COD.	mm	Becchi - Jaws mm	Lettura - Reading mm
9026	0,50	70	0,1

Confezione: plastica / *Supplied in plastic case*



MISURATORE PER STANTUFFI INSPECTION DIAL GAUGE FOR PISTONS

ART. CSC/1 5640

Confezione: plastica / *Supplied in plastic case*

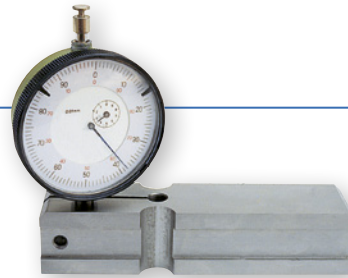
SUPPORTI - STANDS

STATIVO PORTACOMPARATORE CON BASE D'APPOGGIO RETTANGOLARE DIAL GAUGE STAND WITH RECTANGULAR BASE

ART. S042

COD.	Dimensioni base Base dimensions mm	Altezza utile Vertical range mm	Ø colonna Ø column mm
5785	160x100	250	40

Confezione: plastica / *Supplied in plastic case*



SUPPORTO A COLONNA COLUMN STAND

Superficie di controllo in acciaio INOX rettificata e temprata. *Ground hardened stainless steel surface.*

ART. S043

COD.	Dimensioni base Base dimensions mm	Ø colonna Ø column mm
5787	90x130	22

Confezione: plastica / *Supplied in plastic case*

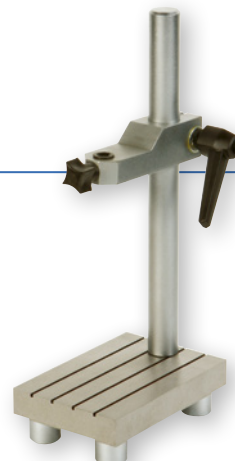

RIGHE PER CONTROLLO STRAIGHT EDGES

Le righe di controllo STORM sono realizzate per garantire un'elevata resistenza all'usura e alla flessione.

STORM rules are high resistant against tear, specially designed to retain shape and accuracy.

RIGHE MILLIMETRATE PER CONTROLLO IN ACCIAIO INOX CON SMUSSO STAINLESS STEEL GRADUATED RULES WITH BEVELED EDGE

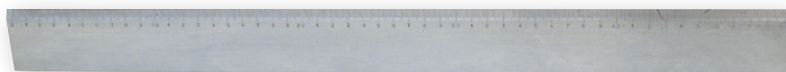

ART. R25

COD.	4020	4021	4022	4023	4024	4025	4026
Lunghezza / Length mm	500	750	1000	1500	2000	3000	4000
Sezione / Cross section mm	30x6	40x8	40x8	40x8	50x10	50x10	60x12

Precisione secondo: Norme DIN866/1 / Accuracy according to DIN 866/1

Confezione: plastica / Supplied in plastic case

RIGHE MILLIMETRATE PER CONTROLLO IN ACCIAIO INOX SENZA SMUSSO STAINLESS STEEL GRADUATED RULES WITHOUT BEVELED EDGE



ART. R30

COD.	4030	4031	4032	4033	4034	4035	4036
Lunghezza / Length mm	500	750	1000	1500	2000	3000	4000
Sezione / Cross section mm	30x6	40x8	40x8	40x8	50x10	50x10	60x12

Precisione secondo: Norme DIN866/1 / Accuracy according to DIN 866/1

Confezione: plastica / Supplied in plastic case

RIGHE MILLIMETRATE PER CONTROLLO IN ACCIAIO GRADUATED STEEL RULES

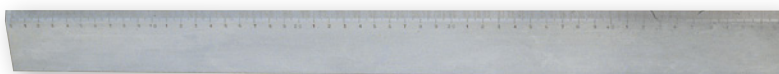

ART. R45

COD.	4050	4051	4052	4053	4054	4055	4056	4057
Lunghezza / Length mm	500	750	1000	1500	2000	2500	3000	4000
Sezione / Cross section mm	30x8	30x8	30x8	40x8	40x8	50x12	50x12	60x12

Precisione secondo: Norme DIN866/1 / Accuracy according to DIN 866/1

Confezione: plastica / Supplied in plastic case

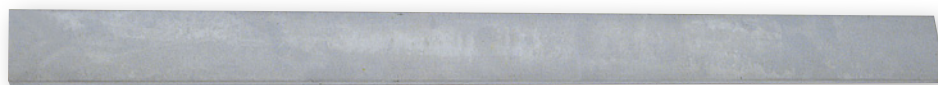
RIGHE PER CONTROLLO - STRAIGHT EDGES
RIGHE DI PRECISIONE IN ACCIAIO NORMALE
STEEL PRECISION RULES

ART. R55

COD.	4070	4071	4072	4073	4074	4075	4076	4077	4078
Lunghezza / Length mm	500	750	1000	1250	1500	2000	2500	3000	4000
Sezione / Cross section mm	40x8	40x10	50x12	60x12	60x12	70x15	70x15	80x20	100x16

Precisione secondo: Norme DIN874/II / Accuracy according to DIN 874/II
 Confezione: plastica / Supplied in plastic case

RIGHE MILLIMETRATE DI PRECISIONE IN ACCIAIO NORMALE
GRADUATED STEEL PRECISION RULES

ART. R60

COD.	4080	4081	4082	4083	4084	4085	4086	4087
Lunghezza / Length mm	500	750	1000	1250	1500	2000	2500	3000
Sezione / Cross section mm	40x8	40x10	50x12	60x12	60x12	70x15	70x15	80x20

Precisione secondo: Norme DIN874/II / Accuracy according to DIN 874/II
 Confezione: plastica / Supplied in plastic case

GUARDAPIANI - KNIFE STRAIGHT EDGES
GUARDAPIANI A COLTELLO
KNIFE STRAIGHT EDGES
ART. G10
ART. G11

Acciaio INOX temprato Hardened stainless steel	Acciaio indeformabile temprato Hardened carbon steel	
COD.	COD.	mm
3999	3959	50
4000	3960	75
4001	3961	100
4002	3962	125
4003	3963	150
4004	3964	200
4005	3965	250
4006	3966	300
4009	3969	350
4007	3967	400
4008	3968	500
4010	3970	600
4011	3971	800
4012	3972	1000

Precisione secondo: Norme DIN874 / Accuracy according to DIN 874
 Confezione: astuccio similpelle / Supplied in leatherette sheath



LIVELLE LEVELS

Le livelle STORM di precisione sono ideali per controlli di planarità, perpendicolarità e parallelismo e per la posa in opera di macchine utensili. La sensibilità delle livelle viene espressa in mm per metro lineare.

STORM precision levels are ideal for checking planarity, straightness and parallelism as well as for the setting up of machine tools.

Accuracy is indicated in mm to a linear meter.

Sensibilità Accuracy mm/m	Sensibilità in valore angolare Accuracy in angle value
1,8	6'
0,35	1' 10"
0,10	20"
0,05	10"
0,04	8"
0,03	6"
0,02	4"
0,01	2"

Sensibilità Accuracy 0,02-0,05	Toll di planarità Flatness accuracy	$\pm (0,005 + \frac{L}{200.000})$ mm
	Toll di ortogonalità Orthogonality tolerance	$\pm (0,002 + \frac{L}{100.000})$ mm
Sensibilità Accuracy 0,10-0,35	Toll di planarità Flatness accuracy	$\pm (0,01 + \frac{L}{100.000})$ mm
	Toll di ortogonalità Orthogonality tolerance	$\pm (0,005 + \frac{L}{50.000})$ mm
Sensibilità Accuracy 1,8	Toll di planarità Flatness accuracy	$\pm (0,02 + \frac{L}{50.000})$ mm
	Toll di ortogonalità Orthogonality tolerance	$\pm (0,01 + \frac{L}{25.000})$ mm

LIVELLE LINEARI A BOLLA D'ARIA LINEAR AIR BUBBLE LEVELS

Base d'appoggio piano
prismatica rettificata.

Stabilized flat prismatic base,
with ground bearing surface.

ART. L100

COD.	Lunghezza / Length mm	Sensibilità / Accuracy mm x 1m
3508	150	0,10
3509	200	0,10
3510	250	0,10
3511	300	0,10
3514	200	0,05
3515	250	0,05
3516	300	0,05
3517	150	0,02
3518	200	0,02
3519	250	0,02
3520	300	0,02

Confezione: cassetta legno / Supplied in wooden case



LIVELLE QUADRE A BOLLA D'ARIA SQUARE BLOCK AIR BUBBLE LEVELS

Superfici d'appoggio piane e
piano prismatiche rettificata.

Flat and flat-prismatic ground
bearing surfaces, finely
adjusted and tested.

ART. L105

COD.	Dimensioni / Dimensions mm	Sensibilità / Accuracy mm x 1m
3546	100x100	0,10
3536	150x150	0,10
3537	200x200	0,10
3538	250x250	0,10
3539	100x100	0,05
3540	150x150	0,05
3541	200x200	0,05
3542	250x250	0,05
3543	150x150	0,02
3544	200x200	0,02
3545	250x250	0,02

Confezione: cassetta legno / Supplied in wooden case



SQUADRE SQUARES

Squadre di precisione STORM per controlli visivi sicuri della planarità e ortogonalità ideali per officine e sale di controllo e collaudo.

STORM precision squares for reliable visual inspection of flatness and orthogonality, ideal for use in workshops and testing rooms.

CON SMUSSO

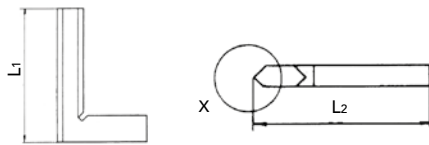

TIPO SEMPLICE

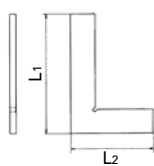

TIPO CAPPELLO



TABELLA TOLLERANZE
ACCURACY TABLE

L ₁	Tolleranze angolarità Angle accuracy			
	00	0	1	2
50	3	-	-	-
75	3	7	14	28
100	3	7	15	30
150	4	8	18	35
200	4	9	20	40
250	5	10	23	45
300	5	11	25	50
500	-	15	35	70
750	-	20	43	85
1000	-	25	60	120
1500	-	35	85	170

FORMULA TOLLERANZE
ACCURACY CALCULATION

Grado di precisione Precision grade	Tolleranza di angolarità Angle accuracy T in µm
00	$2 + \frac{L_1}{100}$
0	$5 + \frac{L_1}{50}$
1	$10 + \frac{L_1}{20}$
2	$20 + \frac{L_1}{10}$

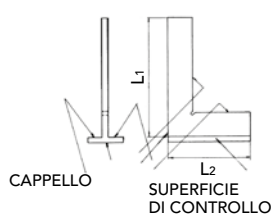
Tolleranza di ortogonalità Orthogonality accuracy				
/1	Tolleranze di ortogonalità secondo il grado di precisione Accuracy of orthogonality in µm referred to precision grades			
	00	0	1	2
			-	-
			14	28
			15	30
			18	35
			20	40
			23	45
			25	50
			35	70
			43	85
			60	120
			85	170

Tolleranza di planarità e rettilineità per squadre da norma DIN 875 a 20°C Accuracy calculation for flatness and straightness of squares according to DIN 875 at 20°C	
Grado Grade	Formula Calculation
00	$\pm (2 + \frac{L}{250}) \mu\text{m}$
0	$\pm (2 + \frac{L}{100}) \mu\text{m}$
1	$\pm (4 + \frac{L}{50}) \mu\text{m}$
2	$\pm (8 + \frac{L}{25}) \mu\text{m}$

L = lato maggiore o minore in mm della squadra
L = longer or shorter square side in mm

Tolleranza di planarità o rettilineità Flatness or straightness accuracy				
/1	Tolleranze di planarità e rettilineità in µm secondo grado di precisione Flatness and straightness accuracies in µm referred to precision grades			
	00	0	1	2
/2				
40	2	-	-	-
50	2	3	5	10
70	2	3	5	11
75	2	3	6	11
100	2	3	6	12
130	3	3	7	13
150	3	4	7	14
165	3	4	7	15
175	-	-	-	15
200	3	4	8	16
250	3	5	9	18
300	3	5	10	20
330	3	5	11	-
375	-	-	-	23
500	4	7	14	28
660	5	9	17	-
750	5	10	19	38
1000	6	12	24	48
1500	8	17	34	68

Tolleranza di ortogonalità per squadre da norma DIN 875 a 20°C Orthogonality accuracy of squares according to DIN 875 at 20°C	
Grado Grade	Formula Calculation
00	$\pm (2 + \frac{L}{100}) \mu\text{m}$
0	$\pm (5 + \frac{L_2}{50}) \mu\text{m}$
1	$\pm (10 + \frac{L_1}{20}) \mu\text{m}$
2	$\pm (20 + \frac{L_1}{15}) \mu\text{m}$

L = lato maggiore in mm della squadra
L = longer square side in mm

Per le squadre bisellate, i valori dati sono validi per una posizione inclinata di ± 15° per un'altezza simmetrica
For the squares with bevelled edges these values apply at an angular freedom of ± 15° to the plane of symmetry

SQUADRE A 90° SEMPLICI IN ACCIAIO INOX TEMPRATO CON PROFILO BISELLATO

90° HARDENED STAINLESS STEEL
BEVELLED EDGE SQUARES

ART. ST/1

COD.	14002	14003	4300	4301	4302	4303
mm	25x20	40x28	50x40	75x50	100x70	150x100
COD.	4304	4305	4306	4307	4308	
mm	200x130	250x160	300x200	400x265	500x330	

Precisione secondo: Norme DIN 875/00 / Accuracy according to DIN 875/00
 Confezione: astuccio similpelle / Supplied in leatherette sheath



SQUADRE A 90° CON CAPPELLO IN ACCIAIO INOX TEMPRATO CON PROFILO BISELLATO

90° HARDENED STAINLESS STEEL
BEVELLED EDGE SQUARES WITH BASE

ART. ST/2

COD.	4320	4321	4322	4323	4324
mm	50x40	75x50	100x70	150x100	200x130
COD.	4325	4326	4327	4328	
mm	250x160	300x200	400x265	500x330	

Precisione secondo: Norme DIN 875/00 / Accuracy according to DIN 875/00
 Confezione: astuccio similpelle / Supplied in leatherette sheath



SQUADRE A 90° SEMPLICI IN ACCIAIO INOX TEMPRATO

90° HARDENED STAINLESS STEEL SQUARES

ART. ST/3

COD.	4330	4331	4332	4333	4334
mm	50x40	75x50	100x70	150x100	200x130
COD.	4335	4336	4337	4338	
mm	250x160	300x200	400x265	500x330	

Precisione secondo: Norme DIN 875/0 / Accuracy according to DIN 875/0
 Confezione: astuccio similpelle / Supplied in leatherette sheath



SQUADRE A 90° CON CAPPELLO IN ACCIAIO INOX TEMPRATO

90° HARDENED STAINLESS STEEL SQUARES WITH BASE

ART. ST/4

COD.	4340	4341	4342	4343	4344
mm	50x40	75x50	100x70	150x100	200x130
COD.	4345	4346	4347	4348	
mm	250x160	300x200	400x265	500x330	

Precisione secondo: Norme DIN 875/0 / Accuracy according to DIN 875/0
 Confezione: astuccio similpelle / Supplied in leatherette sheath



SQUADRA DI ALTA PRECISIONE CON UN LATO VARIABILE

HIGH PRECISION SQUARE MADE OF HARDENED STAINLESS STEEL WITH ADJUSTABLE EDGE

ART. ST/10

COD.	Riga romboidale Rhomboid rule mm	Riga sagomata Profiled rule mm	Base mm
5700	5,5x65	3x2x15	58x25x12

Precisione secondo: Norme DIN 875/0 / Accuracy according to DIN 875/0
 Confezione: plastica / Supplied in plastic case



SQUADRE MULTIGRADI CON CAPPELLO 1/25

modello "onglet"

MULTIGRADES SQUARES WITH BASE, ACCURACY 1/25

"onglet" model

ART. NF/72

COD.	5230	5231	5232
mm	100	120	150
COD.	5233	5234	5235
mm	200	250	300

Confezione: plastica / Supplied in plastic case



SQUADRE A 90° SEMPLICI PER MECCANICI,

IN ACCIAIO INDEFORMABILE

90° WORKSHOP SQUARES MADE OF CARBON STEEL

ART. NF/3

COD.	4600	4601	4602	4603	4604
mm	50x40	75x50	100x70	125x85	150x100
COD.	4605	4606	4607	4608	4609
mm	200x130	250x160	300x200	400x265	500x330
COD.	4610	4611	4612	4613	4614
mm	600x400	750x500	1000x660	1500x1000	2000x1300

Precisione secondo: Norme DIN 875/I / Accuracy according to DIN 875/I
 Confezione: astuccio similpelle / Supplied in leatherette sheath



SQUADRE A 90° SEMPLICI PER MECCANICI,

IN ACCIAIO INDEFORMABILE

90° WORKSHOP SQUARES MADE OF CARBON STEEL

ART. NF/5

COD.	4660	4661	4662	4663	4664
mm	50x40	75x50	100x70	125x85	150x100
COD.	4665	4666	4667	4668	4669
mm	200x130	250x160	300x175	400x200	500x250
COD.	4670	4671	4672	4673	4674
mm	600x300	750x375	1000x500	1500x750	2000x1000

Precisione secondo: Norme DIN 875/II / Accuracy according to DIN 875/II
 Confezione: astuccio similpelle / Supplied in leatherette sheath



SQUADRE A 90° CON CAPPELLO PER MECCANICI, IN ACCIAIO INDEFORMABILE

90° WORKSHOP SQUARES MADE OF CARBON STEEL WITH BASE

ART. NF/4

COD.	4630	4631	4632	4633	4634
mm	50x40	75x50	100x70	125x85	150x100
COD.	4635	4636	4637	4638	4639
mm	200x130	250x160	300x200	400x265	500x330
COD.	4640	4641	4642	4643	4644
mm	600x400	750x500	1000x660	1500x1000	2000x1300

Precisione secondo: Norme DIN 875/I / Accuracy according to DIN 875/I
 Confezione: astuccio similpelle / Supplied in leatherette sheath



SQUADRE A 90° CON CAPPELLO PER MECCANICI, IN ACCIAIO INDEFORMABILE

90° WORKSHOP SQUARES MADE OF CARBON STEEL WITH BASE

ART. NF/6

COD.	4680	4681	4682	4683	4684
mm	50x40	75x50	100x70	125x85	150x100
COD.	4685	4686	4687	4688	4689
mm	200x130	250x160	300x175	400x200	500x250
COD.	4690	4691	4692	4693	4694
mm	600x300	750x375	1000x500	1500x750	2000x1000

Precisione secondo: Norme DIN 875/II / Accuracy according to DIN 875/II
 Confezione: astuccio similpelle / Supplied in leatherette sheath



SQUADRE A 90° SEMPLICI PER MECCANICI, IN ACCIAIO INDEFORMABILE

90° WORKSHOP SQUARES MADE OF CARBON STEEL

ART. NF/7

COD.	4702	4704	4705	4706	4707	4708
mm	100x70	150x100	200x130	250x160	300x175	400x200
COD.	4709	4710	4711	4712	4713	4714
mm	500x250	600x300	750x375	1000x500	1500x750	2000x1000

Precisione secondo: Norme DIN 875/IV / Accuracy according to DIN 875/IV
 Confezione: plastica / Supplied in plastic case



SQUADRE A 90° SEMPLICI PER MECCANICI, IN ACCIAIO INDEFORMABILE, TIPO ECONOMICO

90° WORKSHOP SQUARES MADE OF CARBON STEEL, BASIC MODEL

ART. NF/9

COD.	4740	4741	4742	4743	4744	4745
mm	100x70	150x100	200x130	250x160	300x175	400x200
COD.	4746	4747	4748	4749	4750	4751
mm	500x250	600x300	750x375	1000x500	1500x750	2000x1000

Confezione: plastica / Supplied in plastic case

**SQUADRE A 90° CON CAPPELLO PER MECCANICI,
IN ACCIAIO INDEFORMABILE**
90° WORKSHOP SQUARES MADE OF CARBON STEEL, WITH BASE
ART. NF/8

COD.	4722	4724	4725	4726	4727	4728
mm	100x70	150x100	200x130	250x160	300x175	400x200
COD.	4729	4730	4731	4732	4733	4734
mm	500x250	600x300	750x375	1000x500	1500x750	2000x1000

Precisione secondo: Norme DIN 875/IV / Accuracy according to DIN 875/IV
 Confezione: plastica / Supplied in plastic case

**SQUADRE A 90° CON CAPPELLO PER MECCANICI,
IN ACCIAIO INDEFORMABILE, TIPO ECONOMICO**
**90° WORKSHOP SQUARES MADE OF CARBON STEEL
WITH BASE, BASIC MODEL,**
ART. NF/10

COD.	4760	4761	4762	4763	4764	4765
mm	100x70	150x100	200x130	250x160	300x175	400x200
COD.	4766	4767	4768	4769	4770	4771
mm	500x250	600x300	750x375	1000x500	1500x750	2000x1000

Confezione: plastica / Supplied in plastic case

**SQUADRE A 90° SEMPLICI NICHELATE,
IN ACCIAIO INDEFORMABILE**
90° SQUARES IN NICKEL-PLATED CARBON STEEL
ART. NF/11

COD.	4780	4781	4782	4783
mm	100x70	150x100	200x130	250x160
COD.	4784	4785	4786	
mm	300x175	400x200	500x250	

Confezione: plastica / Supplied in plastic case

**SQUADRE A 90° CON CAPPELLO NICHELATE,
IN ACCIAIO INDEFORMABILE**
90° SQUARES IN NICKEL-PLATED CARBON STEEL WITH BASE
ART. NF/12

COD.	4790	4791	4792	4793
mm	100x70	150x100	200x130	250x160
COD.	4794	4795	4796	
mm	300x175	400x200	500x250	

Confezione: plastica / Supplied in plastic case



SQUADRE A 45° SEMPLICI IN ACCIAIO INDEFORMABILE FLAT 45° CARBON STEEL SQUARES

ART. DR/20

COD.	4840	4841	4842	4843
Lato / Side mm	75	100	125	150
COD.	4844	4845	4846	
Lato / Side mm	200	250	300	

Precisione secondo: Norme DIN 875/II / Accuracy according to DIN 875/II
 Confezione: plastica / Supplied in plastic case

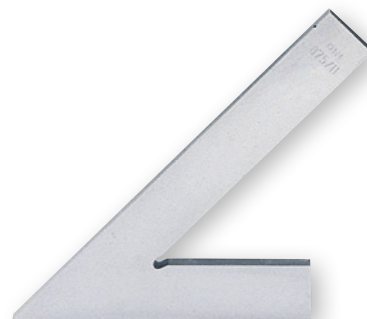

SQUADRE A 45° CON CAPPELLO IN ACCIAIO INDEFORMABILE 45° CARBON STEEL SQUARES WITH BASE

ART. DR/21

COD.	4850	4851	4852	4853
Lato / Side mm	75	100	125	150
COD.	4854	4855	4856	
Lato / Side mm	200	250	300	

Precisione secondo: Norme DIN 875/II / Accuracy according to DIN 875/II
 Confezione: plastica / Supplied in plastic case



SQUADRE A 60° IN ACCIAIO INDEFORMABILE 60° CARBON STEEL SQUARES

ART. DR/22

ART. DR/23

Tipo semplice Plain model	Tipo con cappello Model with base	Lato Side
COD.	COD.	mm
4860	4870	75
4861	4871	100
4862	4872	125
4863	4873	150
4864	4874	200
4865	4875	250
4866	4876	300

Precisione secondo: Norme DIN 875/II / Accuracy according to DIN 875/II
 Confezione: plastica / Supplied in plastic case



DR/22



DR/23

SQUADRE - SQUARES

SQUADRE A 120° IN ACCIAIO INDEFORMABILE 120° CARBON STEEL SQUARES

ART. EX/12		ART. EX/16	
Tipo semplice Plain model		Tipo con cappello Model with base	
COD.		COD.	
mm		mm	
5020		5030	
5021		5031	
5022		5032	
5023		5033	
5024		5034	
5025		5035	

Precisione secondo: Norme DIN 875/II / Accuracy according to DIN 875/II
Confezione: plastica / Supplied in plastic case

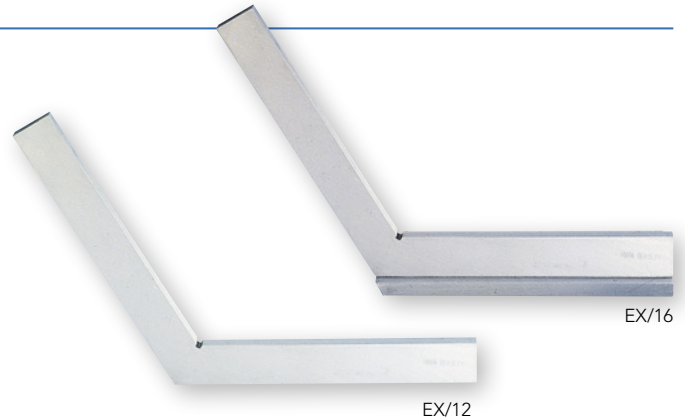

SQUADRE A 135° IN ACCIAIO INDEFORMABILE 135° CARBON STEEL SQUARES

ART. EX/13		ART. EX/17	
Tipo semplice Plain model		Tipo con cappello Model with base	
COD.		COD.	
mm		mm	
5060		5070	
5061		5071	
5062		5072	
5063		5073	
5064		5074	
5065		5075	

Precisione secondo: Norme DIN 875/II / Accuracy according to DIN 875/II
Confezione: plastica / Supplied in plastic case

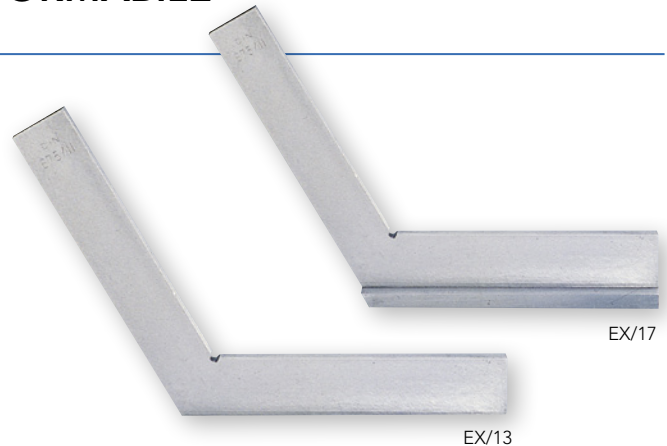

SQUADRE PER MATTONELLE IN ACCIAIO INDEFORMABILE CARBON STEEL SQUARES FOR TILES

ART. CM			
COD.	2370	2371	2372
mm	200	250	300

Confezione: plastica / Supplied in plastic case



SQUADRE A CENTRARE IN ACCIAIO INDEFORMABILE SATINATO PRECISION CENTER SQUARES IN SATIN CARBON STEEL

ART. RL/20				
COD.	4170	4171	4172	4173
mm	100	150	200	250
COD.	4174	4175	4176	
mm	300	400	500	

Confezione: plastica / Supplied in plastic case

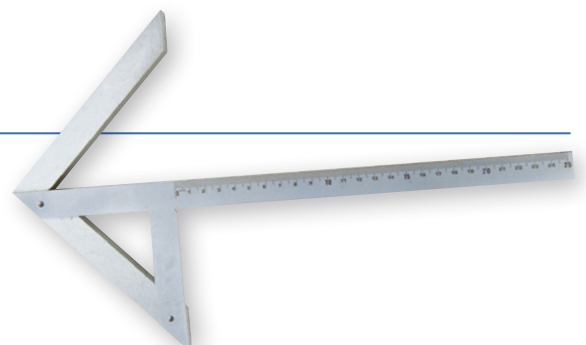

SQUADRA FALSA IN ACCIAIO

STEEL ADJUSTABLE BEVEL SQUARE WITH THUMB SCREW HINGE

ART. S160

COD.	Lunghezza / Length mm
4180	300

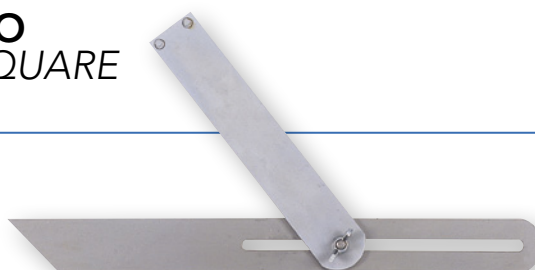

SQUADRE FALSE IN ACCIAIO

STEEL ADJUSTABLE BEVEL SQUARES WITH THUMB SCREW HINGE

ART. S200/1

COD.	4190	4191	4192	4193	4194	4195	4196	4197
mm	100	125	150	200	250	300	400	500

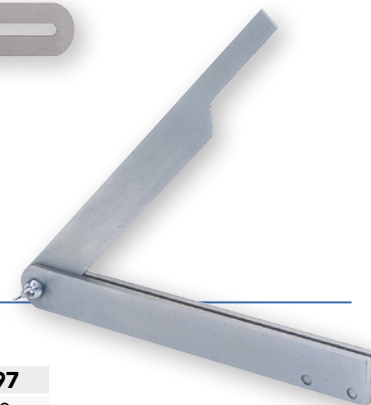

PARALLELE A CROCE IN GHISA G26 UNI 668

PARALLEL "X" BLOCKS IN CAST IRON G26 UNI 668

ART. PO1/1		ART. PO1/2		Dimensioni Dimensions
Tolleranza Accuracy 1/100	COD.	Tolleranza Accuracy 2/100	COD.	
	5400		5410	38x38
	5401		5411	42x42
	5402		5412	60x60
	5403		5413	75x75
	5404		5414	100x80
	5405		5415	120x90
	5406		5416	130x100
	5407		5417	150x100
	5408		5418	200x150

Confezione: plastica / Supplied in plastic case

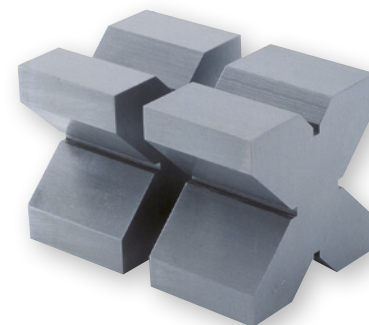

PRISMI AD ANGOLO RETTO IN GHISA G26 UNI 668

90° V BLOCKS IN CAST IRON G26 UNI 668

ART. P30/1		ART. P30/2		Dimensioni Dimensions
Tolleranza Accuracy 1/100	COD.	Tolleranza Accuracy 2/100	COD.	
	5450		5460	75x40
	5451		5461	100x45
	5452		5462	150x55
	5453		5463	200x70
	5454		5464	250x85
	5455		5465	300x105

Confezione: plastica / Supplied in plastic case

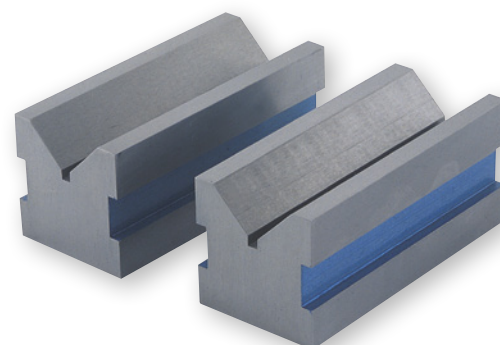

PIANI DI RISCONTRO SURFACE PLATES

I piani di riscontro STORM in ghisa e granito nero sono ideali per controlli dimensionali in sale metrologiche e corredo di officina per tracciature e planarità.

STORM surface plates made of cast iron or black granite are ideal for dimensional measurements in testing rooms and workshops. Useful for tracing operations as well as for checking flatness.

Tolleranza di planarità per i piani da norma DIN 876 a 20°C
Flatness accuracy of plates according to DIN 876 at 20°C

Grado / Grade	Formula / Calculation
00	$\pm (0,001 + \frac{L}{1.000.000}) \mu\text{m}$
0	$\pm (0,001 + \frac{L}{5.000.000}) \mu\text{m}$
1	$\pm (0,002 + \frac{L}{2.500.000}) \mu\text{m}$
2	$\pm (0,005 + \frac{L}{5.000.000}) \mu\text{m}$
3	$\pm (0,02 + \frac{L}{50.000}) \mu\text{m}$

L = Lato maggiore del piano espresso in mm
L = Longest plate side indicated in mm

PIANI IN GHISA NORMALIZZATA G26 SURFACE PLATES MADE OF SPECIAL CAST IRON G26

ART. P14/1 rettificato; tolleranza 1/100 / ground; accuracy 1/100

ART. P14/2 rettificato; tolleranza 2/100 / ground; accuracy 2/100

ART. P14/3 piattato; tolleranza 3/100 - oltre 300 mm piattato a riquadri / planed; accuracy 3/100 - over 300 mm squared planed

ART. P14/1			ART. P14/2			ART. P14/3			Dimensioni / Dimensions mm
5500	5530								150x200
5501	5531								150x250
5502	5532								200x300
5503	5533								250x250
5505	5535								300x300
5506	5536	5562							300x400
5507	5537	5563							300x500
5508	5538	5564							400x500
5509	5539	5565							400x600
5511	5541	5567							500x600
5512	5542	5568							500x800
5513	5543	5569							600x800
5514	5544	5570							700x1000
5517	5547	5573							1000x1000
5521	5551	5577							1000x1500
5522	5552	5578							1000x2000
5523	5553								1000x2500
5524	5554								1500x2000

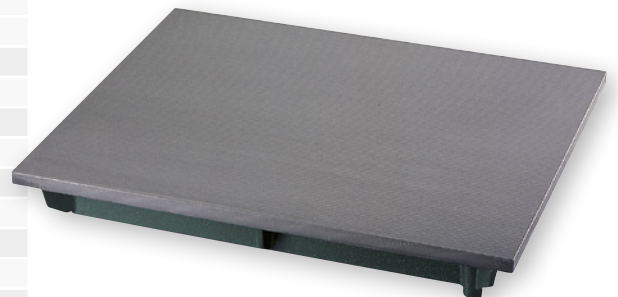

COLONNE DI SOSTEGNO IN GHISA G22 PER PIANI DI RISCONTRO SUPPORTING FEET MADE OF CAST IRON G22 FOR SURFACE PLATES

ART. P16

COD.	Dimensioni Dimensions mm	Viti Screws
5660	700x830	1
5661	520x600	1
5662	520x640	2

ARTICOLI NON PRODOTTI DA STORM ARTICLES NOT BELONGING TO STORM PRODUCTION

PIANI DI RISCONTRO E CONTROLLO IN GRANITO NERO BLACK GRANITE SURFACE PLATES

CARATTERISTICHE TECNICHE – TECHNICAL DATA			
Durezza	Hardness		7÷8,5 gradi MOHS 60 -70 HRC
Peso specifico	Specific weight	kg/dm ³	3
Porosità	Porosity		0,76%
Resistenza alla compressione	Load resistance	kg/cm ²	1.600 ÷ 2.400
Resistenza alla flessione	Bending resistance	kg/cm ²	100 ÷ 175
Coefficiente di dilatazione termica lineare	Linear expansion	°C ⁻¹	(5 ÷ 6,7) x 10 ⁻⁶
Conducibilità termica	Thermal conductivity	kcal (m.h. °C)	2,5 ÷ 3,4
ART. PRG/B	Adatto per sale di controllo For quality control and testing rooms	Grado laboratorio Precision grade	$\pm 1 \mu + \frac{L^*}{500.000}$
ART. PRG/D	Adatto per controlli normali in reparti di lavorazione For ordinary workshop tests	Grado laboratorio Precision grade	$\pm 5 \mu + \frac{L^*}{200.000}$

ART. PRG/B		ART. PRG/D		Dimensioni Dimensions	Peso Weight
Grado / Grade	Grado / Grade	Grado / Grade	Grado / Grade		
00	0	00	0	mm	kg
COD.	± μ	COD.	± μ		
9333	3	9373	6	300x200x50	9,6
9334	3	9374	6	300x300x70	20,1
9335	3	9375	6	400x250x70	22,4
9336	3	9376	6	400x400x70	35,8
9337	4	9377	7	630x400x100	80
9338	4	9378	7	630x630x100	127
9339	4	9379	8	800x500x100	128
9340	4	9380	8	1000x630x150	300
9341	4	9381	8	1000x750x150	339
9342	4	9382	8	1000x1000x150	453
9343	5	9383	9	1200x800x150	434
9344	6	9384	11	1600x1000x200	965
9345	6	9385	12	2000x1000x200	1207



TAVOLI DI SUPPORTO PER PIANI DI RISCONTRO IN GRANITO STANDS FOR GRANITE SURFACE PLATES

Regolazione altezza mezzo viti. Height adjustable by screws.

ART. TAV		
COD.	COD.	Dimensioni Dimensions mm
senza cassetto without drawer	con cassetto with drawer	
5663	5663C	630x400
5664	5664C	630x630
5665	5665C	800x500
5666	5666C	1000x630
5667	5667C	1000x750
5668	5668C	1000x1000
5669	5669C	1200x800
5670	5670C	1600x1000
5679	5679C	2000x1000

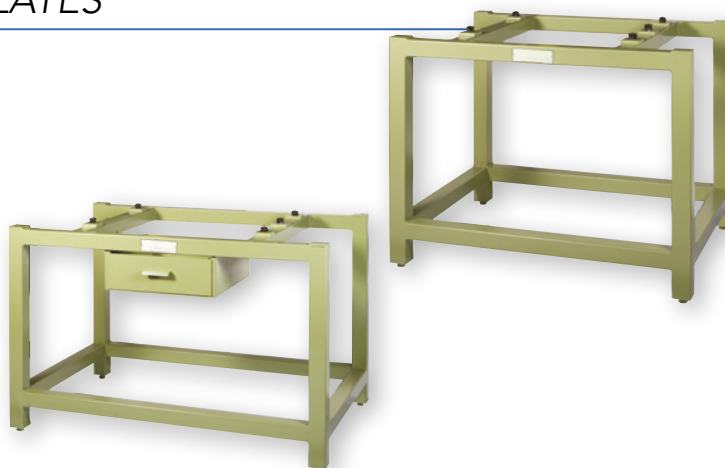

SQUADRE DI CONTROLLO IN GRANITO / GRANITE SQUARES

ART. SGC/A					
COD.	Dimensioni / Dimensions mm	μ	COD.	Dimensioni / Dimensions mm	μ
4396	100x63x17	3	4398	250x160x25	5
4397	160x100x19,5	4	4399	400x250x41	6
			4400	630x400x62	9
			4401	1000x630x82	12





LTF S.p.A.

24051 ANTEGNATE (BG) ITALY - VIA CREMONA, 10
TEL. +39 0363 94901 (15 linee r.a.) - FAX +39 0363 914770-914797
CAPITALE SOCIALE € 12.500.000 i.v.
R.E.A. BG n. 189980 - Registro Imprese BG, C.F. e P.IVA 01276740162
COD. ID. CEE IT 01276740162 - EXPORT BG 002668
ltf@ltf.it - www.ltf.it